

AC Leakage Current Probe Model 2620



The Model 2620 measures leakage current shunted to ground caused by insulation faults. It enables the operator to locate failures when they occur, or anticipate them before they occur, without shutting down equipment or spending hours troubleshooting.

It is designed specifically for locating low current faults on high current loads. The detector is a sensitive AC current transformer capable of measuring differential or leakage current as low as $500\mu\text{A}$, and may be used to measure current up to 400A continuous.

The Model 2620 provides two output ranges: $1\text{mV}/\text{mA}_{\text{AC}}$ or $1\text{mV}/\text{A}_{\text{AC}}$. The

output leads are terminated with standard 4mm banana plugs capable of interfacing with any standard multimeter. The use of a digital multimeter with analog bargraph is recommended; Digital to provide accurate readings, and an analog bargraph to track trends.

The Model 2620 measures leakage currents on single or multi-phase systems. Currents measured may be in or out of phase, balanced or unbalanced.

Principle (see page 4): when clamping around all conductors, the net magnetic field at any instant in time will be zero if all the conductors surrounded by the leakage current

detector are supplying all the current delivered to and received from the load. If any current is diverted through any alternate path, such as an insulation breakdown to ground, the net loss will be detected producing an output proportional to the amplitude of the fault current.

The Model 2620 may also be used as a highly accurate clamp-on current probe. With its 4" jaw opening and range of $500\mu\text{A}$ to 200A, the Model 2620 provides a versatile way to analyze unbalanced current measurements, leakage values on grounding conductors and ground loop currents.

Features

- Very high sensitivity
- Differential or leakage current from 500 μ A
- Current up to 400A
- Two switch-selectable measurement ranges: 4A_{AC}/400A_{AC}
- Large inside jaw diameter (>4") allows use on large or multiple conductors
- Work with single-, dual- and three-phase networks
- Connect directly to DMMs on mV or VAC range

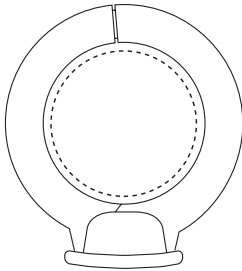

Jaw Opening: 4.4" (112mm)
Conductor Size: 4.4" (112mm)

Applications

- Preventive maintenance
- Equipment troubleshooting on electrical distribution systems
- High accuracy low-current measurements
- Measure fault currents on three-phase, three-wire systems



Model 2620 includes double reinforced 5 ft (1.5m) leads with 4mm safety banana plugs



Model 2620 checking for ground fault currents

Specifications

MODEL		2620	
ELECTRICAL			
		4A Range	400A Range
Current Range		500 μ A to 4A	500mA to 400A
Output Signal		1mV/mA (4V max)	1mV/A (400mV max)
Accuracy	500 μ A to 10mA	3% of Reading \pm 1mV	–
	10mA to 100mA	0.5% of Reading \pm 0.5mV	–
	100mA to 4A	0.5% of Reading \pm 0.5mV	–
	500mA to 10A	–	0.5% of Reading \pm 0.5mV
	10A to 100A	–	0.35% of Reading \pm 0.5mV
	100A to 400A	–	0.35% of Reading \pm 1mV
Phase Shift	10mA to 100mA	<15°	–
	100mA to 4A	<10°	–
	10A to 100A	–	<1°
	100A to 400A	–	<0.6°
Load Impedance (DMM)		1M Ω min	1M Ω min
Frequency Range		48 to 1000Hz	48 to 1000Hz
Output Termination		5 ft (1.5m) Lead with 4mm safety banana plugs	5 ft (1.5m) Lead with 4mm safety banana plugs
MECHANICAL			
Dimensions		11.22 x 6.89 x 1.77" (285 x 175 x 45mm)	
Jaw Opening		4.4" (112mm)	
Maximum Conductor Size		4.4" (112mm)	
Weight		2.87 lbs (1300g)	
ENVIRONMENTAL			
Operating Temperature		-14° to 131°F (-10° to 55°C); 0 to 85% RH (non-condensing)	
Storage Temperature		-40° to 158°F (-40° to 70°C); 0 to 85% RH (non-condensing)	
SAFETY			
Safety Rating		EN 61010-2-032, 600V Cat. III	
Double Insulation <input type="checkbox"/>		Yes	
CE Mark		Yes	

Typical Points for Measuring Leakage Current

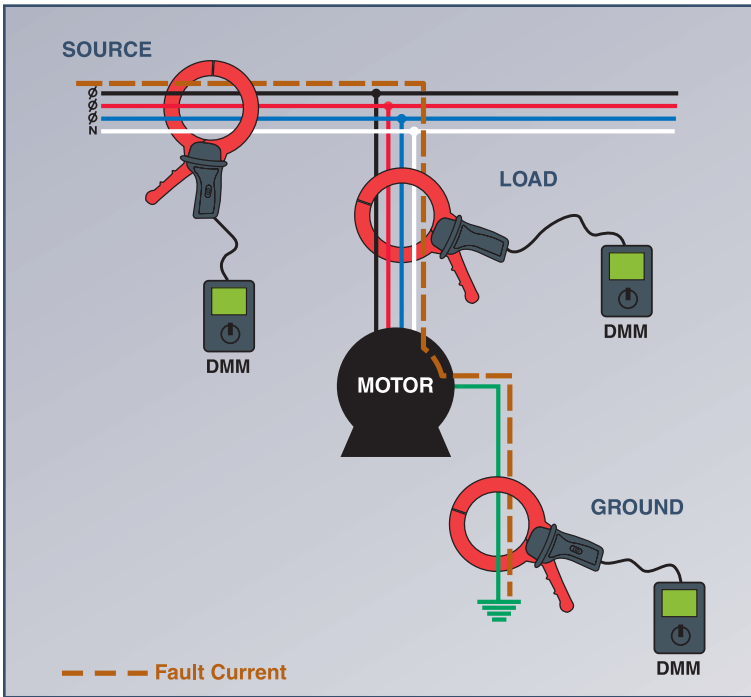

On multi-phase systems, the Model 2620 can be used with a standard multimeter to measure leakage current at the source, the load or at the ground.

Construction



ORDERING INFORMATION	CATALOG NO.
AC Leakage Current Probe Model 2620 (4A, 1V/A & 400A, 1mV/A output)	Cat. #2125.52
Accessories (Optional)	
Artificial Neutral Model AN-1	Cat. #1971.01

Contact Us

United States & Canada:

Chauvin Arnoux[®], Inc.
d.b.a. AEMC[®] Instruments
200 Foxborough Blvd.
Foxborough, MA 02035 USA
(508) 698-2115 • Fax (508) 698-2118
www.aemc.com

Customer Support – for placing an order, obtaining price & delivery:
customerservice@aemc.com

Sales Department – for general sales information:
sales@aemc.com

Repair and Calibration Service – for information on repair & calibration, obtaining a user manual:
repair@aemc.com

Technical and Product Application Support – for technical and application support:
techinfo@aemc.com

Webmaster – for information regarding www.aemc.com:
webmaster@aemc.com

South America, Central America, Mexico, Caribbean, Australia & New Zealand:

Chauvin Arnoux[®], Inc.
d.b.a. AEMC[®] Instruments
15 Faraday Drive
Dover, NH 03820 USA
(978) 526-7667 • Fax (978) 526-7605
export@aemc.com
www.aemc.com

All other countries:

Chauvin Arnoux SCA
190, rue Championnet
75876 Paris Cedex 18, France
33 1 44 85 45 28 • Fax 33 1 46 27 73 89
info@chauvin-arnoux.com
www.chauvin-arnoux.com