

REED

Model VC01 Temperature Calibrator

Instruction Manual



[www reedinstruments com](http://www.reedinstruments.com)

Table of Contents

Safety	3
Specifications	4-5
Instrument Description	6-7
Operating Instructions	8-15
<i>ON/OFF</i>	8
<i>Automatic Power Off</i>	8
<i>Outputs</i>	8-12
<i>Calibration</i>	13-15
Battery Replacement	16

For service (repairs or calibration) on this or any other REED product or information on other REED products, contact REED Instruments at info@reedinstruments.com



Safety Information

To ensure the safety operation, the following signs are used only as specified in this instruction manual.

⚠ WARNING Indicates that the current operation does not comply with correct instruction. Therefore causing potential hazards to the user or instrument. Also indicates how to avoid such hazards.

! CAUTION Indicates that if the current operation does not comply with correct instruction. Therefore causing potential hazards to the instrument. Also indicates how to avoid incorrect operation.

NOTE Serves as a sign to remind the user that they must understand the correct operation of the simulator and its characteristics.

To prevent the user and the instrument from electric shock and other hazards, it is necessary to follow the following regulations:

Warning - **⚠ WARNING**

- Do not operate the instrument where flammable gas or explosive gas or vapor are exposed. This is extremely dangerous
- Never apply more than 30V between any two terminals, or between any terminal and ground

Caution - **! CAUTION**

- The split case (top and bottom) is not to be removed, unless by qualified technicians
- To clean the instrument, periodically wipe the case with a damp cloth and mild detergent, do not use any corrosive solvents

Note - **NOTE**

- For optimal accuracy, allow the instrument to warm up 5 minutes before operating
- If the automatic reference-junction temperature compensation of the instrument deviates from its designed accuracy, contact a qualified REED technician

Specifications - Output Functions

Applicable range from 18 to 28°C, within one year after calibration

Output	Range	Output Range	Resolution	Accuracy	Note
DCV	100mV	-10.00mV to 110.00mV	0.01mV	0.05% of set value 30μV	Max. output current ±2mA
	10000 mV	-100.00mV to 1100.00mV	0.1mV	0.05% of set value 0.3mV	
OHM	400Ω	0.0 to 400.0Ω	0.1Ω	±0.05% of set value ±0.2Ω	1mA excit. current
TC	R	-40 to 1760°C	1°C	±0.05% of set value ±3°C (≤100°C) ±0.05% of set value ±2°C (>100°C)	By using ITS-90 temperature scale
	S	-20 to 1760°C	1°C		
	B	400 to 1800°C	1°C	±0.05% of set value ±3°C (400°C to 600°C) ±0.05% of set value ±2°C (>600°C)	
	E	-200.0 to 000.0°C	0.1°C	±0.05% of set value ±2°C (≤-100°C) ±0.05% of set value ±1°C (>-100°C)	
	K	-200.0 to 370.0°C	0.1°C		
	J	-200.0 to 200.0°C	0.1°C		
	T	-200.0 to 400.0°C	0.1°C		
	N	-200.0 to 1300.0°C	0.1°C		
	RTD	Pt100	-200 to 850.0°C	0.1°C	
C _μ 50		-50.0 to 150°C	0.1°C		

Note 1: Without accessory lead resistance

Note 2: Range of exciting current: 0.5mA to 2mA; max. output voltage: ≤2V

- The accuracies indicated do not include the error of internal temperature compensation caused by a sensor. The range of the internal temperature compensation sensor is from -10 to 50°C with its compensating error up to 0.5°C
- Temperature coefficient: ±0.005% of range per °C for the temperature ranges from 0 to 18°C and from 28 to 50°C

General Specifications

Operating temperature:	0°C to 50°C
Operating relative humidity:	≤80% RH
Storage temperature:	≤-10°C to 55°C
Storage humidity:	≤90% RH
Max. permitted voltage:	30V (between any two terminals or between any terminal and ground)
Power supply:	Single 9V battery (ANSI/NEDA 1604A or IEC6LR619V alkaline)
Battery life:	Approximately 12 hours
Dimensions:	200 × 100 × 40mm (with holster)
Weight:	550g (with holster)
Includes:	Set of CF-36 industrial test lead (with alligator clips) and Instruction manual
Safety:	Certified compliant to IEC1010 provisions (Safety Standard issued by International Electro-technical Commission)

For service on this or any other REED product or information on other REED products, contact REED Instruments at info@reedinstruments.com



Instrument Description

- 1 - LCD display area
- 2 - Power ON/OFF button
- 3 - °C/°F Interchange button
- 4 - RJ-ON button (TC ref-junc comp)
- 5 - Output Zero Reset button
- 6 - Function Selection button
- 7 - Range Selection key
- 8 - ◀▶ Output Digit Selection button
- 9 - ▲▼ Output Value Setting button
- 10 - Output terminal

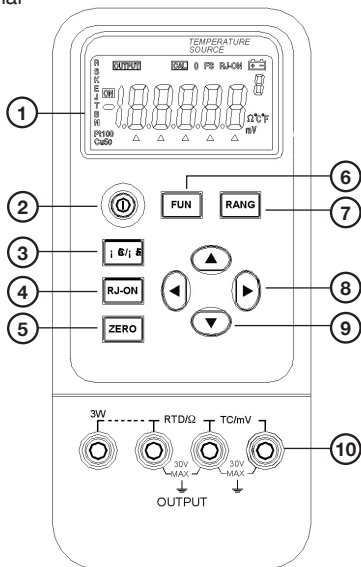

Display Description

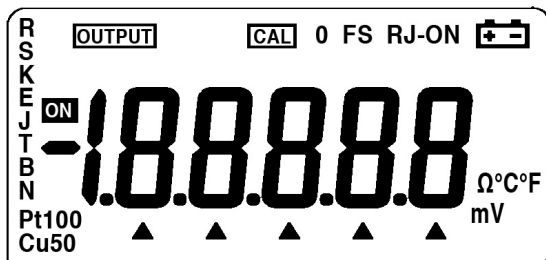

OUTPUT	Indicates that the instrument is in an output state
CAL	Indicates that the instrument is in a calibration state
0 FS	Indicates that the instrument is in a calibration state, denoting that the zero point or the full scale point is now in calibration
RJ-ON	Indicates that the instrument is performing its reference-junction compensation (Refer to subsection 5.2)
	Indicates that the battery power is low and needs to be replaced (Refer to subsection 3.1)
	Indicates that the output digits need to be set
Ω°C°F mV	Indicates the current output value (unit of measure)
ON	Indicates that the output signal is on
R E B S J N K T	Indicates the type of thermocouple
Pt100 Cu50	Indicates the respective type of a RTD

Operating Instructions

Power ON/OFF

Power-key operation

Press the Power ON/OFF button (#2 on page 6) to turn the instrument on. Press this button again, holding for one second to turn the instrument off. When the instrument is on, it will begin an internal self-diagnosis at which time the full screen will be displayed (#1 on page 6). Once complete, the instrument is ready to be used.

Automatic power-off

As a default the instrument will be set to automatically turn itself off after 10 minutes with button operation. To turn off this feature:

- 1) Turn the instrument off
- 2) Press the Power ON/OFF button (to display the full screen)
- 3) Press the RANG button (#7 on page 6) when the instrument is in the maintenance state. AP-XX will display
- 4) Press the ▼ button (#9 on page 6) when AP-ON is displayed. AP-OF will now be displayed, indicating that the automatic power-off is not on
- 5) Press the Power ON/OFF button to exit the maintenance state and turn the instrument off

Outputs

The output terminal of the instrument can produce DC voltages set by the user or simulating resistance.

! CAUTION Do not apply any voltage to the output terminal during the operation. If any improper voltage is applied to the output terminal, it will cause damage to the internal circuit.

continued ...

Output Operation Procedure

Function Operation	Range Operation	Display	Set Range
DCV 1 V	1 V ←	0.0000 V	-0.1000 to 1.1000 V
	↓		
	100mV ←	000.00 mV	-10.00 to 110.00 mV
		000.0Ω	000.0 to 400.0Ω
OMH 400 Ω			
↓			
TC R	R ←	0000°C	-40 to 1760°C
↓	↓		
	S	0000°C	-20 to 1760°C
	↓		
	K	0000.0°C	-200 to 1370°C
	↓		
	E	0000.0°C	-200 to 1000°C
	↓		
	J	0000.0°C	-200 to 1200°C
	↓		
	T	0000.0°C	-200 to 400°C
	↓		
	B	400 °C	400 to 1800°C
	↓		
	N	0000.0°C	-200 to 1300°C
↓	←		
RTD Pt100	Pt100	000.0 °C	-200 to 850°C
	↕		
	Cμ50	000.0 °C	-50 to 150°C

DC Voltage Output

- 1) Insert one end of the test lead into the output (TC/mV) jack of the instrument and connect the other end to the input of the instrument, as shown in the diagram to the right
- 2) Press the FUN (Function) button to select the V function when the unit 'V' appears in the display
- 3) Press the RANG (Range) Button to select the range of 1.0000V or 100.00mV when the display indicates the unit 'V' or 'mV'
- 4) Press the ◀▶ button to select the set digits for output
- 5) Press the ▲ ▼ button to change the numerical value of the set digits. Hold the button for one second and the value will keep varying
- 6) Press the ZERO button and the output will be set to 00.00mV or 0.0000V

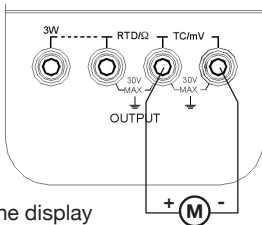

Simulating output from thermocouple (TC)

- 1) Insert one end of the test lead into the output (TC/mV) jack of the instrument and connect the other end to the input of the instrument. As shown in the above diagram
- 2) Press the Fun (Function) button to select the function of a thermocouple and the display will indicate the unit °C or the type of R
- 3) Press the RANG (Range) button to select an appropriate type
- 4) Press the ◀▶ button to select the set digits for output
- 5) Press the ▲ ▼ button to change the numerical value of the set digits. Hold the button for one second and the value will keep varying
- 6) Automatic compensation for reference-junction temperature

continued ...

During the direct calibration of an instrument with reference-junction temperature compensation, it is common to press the RJ-ON button so that the instrument can start the function of automatic reference-junction compensation. Thus providing the required thermo-electromotive force for output followed by displaying the symbol RJ-ON where:

output emf = emf corresponding to the set temperature
– emf corresponding to the room temperature

- It takes two seconds for the instrument to start its internal reference-junction temperature. After this, each automatic compensation takes place at 10 second intervals
 - If there is a change in the operating ambient temperature, do not start the operation until the built-in compensating sensor has become stable (ca. 10 minutes)
 - If there is no need for the Simulator to perform the function of automatic reference-junction compensation, press the RJ-ON button and the symbol RJ-ON will no longer appear in the display
- 7) Press the ZERO button and the output will be directly set to 0000°C (R or S type), 400°C (B type) or 0000.0°C (other type)
- 8) Press the °C/°F button to select the unit ‘°C’ or ‘°F’

Simulating output from resistance or RTD

NOTE

Resistance-simulation: The instrument produces the simulation resistance up to 400Ω at its output terminal (RTD /Ω). The method of simulating resistance output is to send out an appropriate voltage ‘VX’ according to the exciting current ‘IX’ produced by the calibrated instrument. Because R (set resistance) = VX (output voltage) / IX (exciting current), the calibrated device must provide an exciting current to the simulator. The exciting current should range from 0.5mA to 2mA.

continued ...

NOTE

Resistance-simulation: A 4-wire system is designed for the resistance output during the calibration. If you adopt a two-wire system, you should take into consideration the error (ca.0.1 Ω) arising from the lead resistance of the test leads. If the capacitance between the resistance output terminal of the simulator and the tested instrument is more than 0.1 μ f, the simulator will produce improper resistance.

- 1) Insert one end of the test lead into the output (RTD/ Ω) jack of the instrument and connect the other end to the input of the instrument as shown in the diagram to the right. The dedicated test leads supplied with the simulator can be made into a 3-wire or 4-wire system for testing output according to user's requirement
- 2) The display of the symbol 'OUTPUT' denotes the instrument is in an output state
- 3) Press the FUN (Function) button to select the function of resistance or RTD when the unit ' Ω ' or ' $^{\circ}$ C' and the type of the RTD 'Pt100' appears in the display
- 4) During the use of the RTD function, press the RANG (Range) button to select a corresponding type
- 5) Press the \blacktriangleleft \blacktriangleright button to select the set digits for output
- 6) Press the \blacktriangle \blacktriangledown button to change the numerical value of the set digits. Hold the button for one second and the value will keep varying
- 7) Press the Zero button and the output will be directly set to 000.0 $^{\circ}$ C
- 8) Press the $^{\circ}$ C/ $^{\circ}$ F button to select the unit $^{\circ}$ C or $^{\circ}$ F

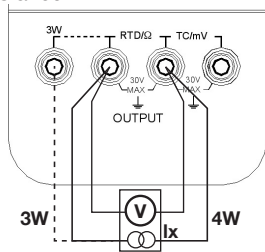

Calibration

NOTE

To ensure accuracy of the instrument, it is recommended to calibrate your instrument once a year. It is recommended that the following standards be used to perform the calibration.

! CAUTION

During the operation, avoid any short circuit and never apply more than the maximum permitted voltage to the output of the simulator and the co-working standard device, incorrect operation may cause damage to the internal circuits.

Selecting Standard Equipment

Calibration Item	Stand. Equip.	Output Range	Accuracy	Recommend
DCV 100mV	digital meter	max.110mV	$\pm(10\text{ppm}+1\mu\text{V})$	1281 (FLUKE) 5520 (FLUKE) or equivalent
1V		max.1.1V	$\pm(10\text{ppm}+5\mu\text{V})$	
OHM 400 Ω	digital meter	max. 2V stand. equip. $\pm 1\text{mA excit.}$	$\pm(10\text{ppm}+5\mu\text{V})$ $\pm(80\text{ppm}+0.03\mu\text{A})$	

Ambient Condition for Calibration

Ambient temp.: 23°C \pm 1°C

Relative humidity: 45 to 75% RH

Warming up: The standard equipment must be warmed up to the given time. Do not connect the instrument to the power supply until it has been exposed to the calibrating ambient condition for 24 hours. Then set the instrument to a state of non-automatic shutdown followed by warming it up for 30 minutes.

NOTE Power supply for calibration: During the calibration, the battery needs replacing.

Operating Output Calibration

Operate output calibration in the order of items and calibration points:

Item #	Output Range	Calibration Point
1	DCV/1V	0
		FS
		0 FS
2	DCV/100mV	0
		FS
3	OHM/400Ω	0
		FS
		0
		-FS

1V Range Calibration

- 1) The calibration wiring is shown in the diagram to the right
- 2) Press the FUN & RANG buttons first, and then press the POWER to enter the simulator in a state of 1V output calibration when the symbols 'OUTPUT', 'CAL 0', 'ON' and the unit 'V' appear in the display
- 3) Set the digital meter to an appropriate range
- 4) With the output stabilized, operate the ◀▶ and ▲ ▼ buttons to set the indication of the simulator with the reading of the digital meter
- 5) Press the ZERO button and the display will flash, denoting that the calibrated point has been stored
- 6) Press the RANG button to display the symbol 'CAL FS'. With the output stabilized, repeat steps 4 & 5
- 7) Press the RANG button to display the symbol 'CAL 0 FS'. With the output stabilized, repeat steps 4 & 5

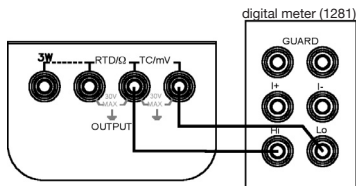

NOTE

Calibration Storage: Press the ZERO button to store the calibrated point when the display does not flash, denoting that the calibration storage is invalid.

100mV Range Calibration

- 1) The calibration wiring is shown in the diagram shown on Page 14
- 2) Press the FUN button to enter the simulator in a state of 100mV output calibration when the display indicates the symbols 'OUTPUT', 'CAL 0', 'ON' and the unit 'mV'
- 3) Repeat the operation of steps 3 to 6 in 1V Range Calibration on Page 14

Resistance Calibration

- 1) The calibration wiring is shown in the diagram to the right
- 2) Press the FUN button to enter the simulator in a state of resistance output calibration when the display indicates the symbols 'OUTPUT', 'CAL 0', 'ON' and the unit ' Ω '
- 3) Set the digital meter and standard source to an appropriate range, and then set the standard source to +1mA output
- 4) With the output stabilized, repeat steps 4 & 5 in 1V Range Calibration on Page 14
- 5) Press the RANG button to display the symbol 'CAL FS'. With the output stabilized, repeat steps 4 & 5 in 1V Range Calibration on Page 14
- 6) Change the output of the standard source to -1mA output
- 7) Press the RANG button to display the symbols 'CAL 0' & '-'. With the output stabilized, repeat steps 4 & 5 in 1V Range Calibration on Page 14
- 8) Press the RANG button to display the symbols 'CAL FS' & '-'. With the output stabilized, repeat steps 4 & 5 in 1V Range Calibration on Page 14

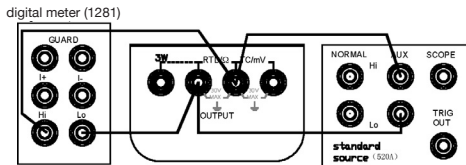

NOTE

Exciting current: The flow direction of the exciting current must be in line with the calibration point, otherwise the display fails to flash, denoting that the calibration storage is invalid.

Replacing the Battery

⚠WARNING

Remove the test leads and turn the instrument off before replacing the battery.

When the low battery  symbol appears in the display, indicating the battery power is low and the battery needs to be replaced.

Follow these steps:

- 1) Remove the test leads and turn the instrument off
- 2) Remove the holster from the instrument. Open the battery cover at the back of the instrument by unlocking it in the direction indicated
- 3) Replace the old battery with a new one. Put the battery cover back and lock it in the direction indicated

Notes

For service on this or any other REED product or information on other REED products, contact REED Instruments at info@reedinstruments.com

