

REED



Model SD-8205

Vibration Meter/ Datalogger



Instruction Manual

[www reedinstruments com](http://www.reedinstruments.com)

Table of Contents

Features.....	3
Specifications.....	3-4
Instrument Description.....	5
Operating Instructions.....	6-10
<i>Changing Unit</i>	6
<i>Function selection</i>	6
<i>Zero Adjustment</i>	7
<i>Max hold reset procedures</i>	7
<i>Data Hold</i>	7
<i>Data Record</i>	7-8
<i>Backlight ON/OFF</i>	8
<i>Datalogger</i>	8
<i>Auto Datalogger</i>	8-9
<i>Manual Datalogger</i>	9
<i>Checking the Time</i>	9
<i>Check Sampling Time Information</i>	9
<i>SD Card Data Structure</i>	10
<i>Data Transfer from SD card to Computer</i>	10
Advanced Settings.....	11-12
<i>Set Clock Time</i>	11
<i>Setting the Decimal point on the SD Card</i>	11
<i>Auto power OFF management</i>	12
<i>Set Beeper Sound ON/OFF</i>	12
<i>Set sampling time</i>	12
<i>SD memory card Format</i>	12
PC Serial Interface.....	13
System Reset.....	14
Battery Replacement.....	14

Features

- Frequency range meets ISO 2954 standards
- Metric & Imperial display units
- Separate vibration probe with magnetic base
- Measures Velocity & Acceleration
- RMS, Peak, & Max Hold functions
- Real time SD memory card datalogger with a built-in clock and calendar
- Sampling time set from 1 second to 3600 seconds
- Meter can switch to a Manual Datalogging
- No extra software needed, just plug the SD card into the computer and it downloads directly to EXCEL
- SD card capacity: 1 GB to 16 GB
- Easy to read LCD with backlight
- Auto power off or manual power off
- Data hold, record max. and min. reading
- High accuracy microcomputer circuit
- Power by UM3/AA (1.5 V) x 6 batteries
- USB/RS232 Computer interface

Specifications

Circuit:	Custom microprocessor LSI circuit
Display:	52mm x 38mm LCD with backlight
Frequency Range:	10Hz - 1KHz
Auto Sampling Time:	1, 2, 5, 10, 30, 60, 120, 300, 600, 1800, 3600 seconds
Memory Card:	SD memory card, 1 GB to 16 GB
Sampling Time:	Approx. 1 second
Data Output:	USB/RS232 PC computer interface
Temperature Range:	0-50°C (0-122°F)
Resolution:	0.1°C/0.1°F

Accuracy:	± 0.8°C/1.5°F
Operating Temperature:	0-50°C (0-122°F)
Operating Humidity:	Less than 85% R.H.
Power Supply:	UM3/AA (1.5 V) x 6 batteries
Weight:	Main instrument 515g/1.13lb, Probe 99g/.22lb
Dimensions:	Main instrument 203 x 76 x 38mm, Probe 37mm 16mm Dia, Cable Length 1.2m
Includes:	Vibration sensor with cable, magnetic base, hard carrying case, and batteries
Optional accessories:	4G SD Card (SD-4GD) External Probe (SD-8205PROBE) USB cable (USB-01) Power adapter (AP-9VA-110V) Data Acquisition Software (SW-U801-WIN) Tripod (BS-6)

Visit us at www.reedinstruments.com for more information on our Optional Accessories, or e-mail us at info@reedinstruments.com

Acceleration

Units	m/s ²	g	ft/s ²
Range	0.5 - 199.9m/s ²	0.05 - 20.39g	2 - 656ft/s ²
Resolution	0.1m/s ²	0.01g	1ft/s ²
Accuracy	±(5% + 2d)		
Calibration Point	50m/s ²		

Velocity

Units	mm/s	cm/s	inch/s
Range	0.5-199.9mm/s	0.05-19.99cm/s	0.02-7.87inch/s
Resolution	0.1mm/s	0.01cm/s	0.01inch/s
Accuracy	±(5% + 2d)		
Calibration Point	50mm/s		

For service on this or any other REED product or information on other

REED

www.reedinstruments.com

4

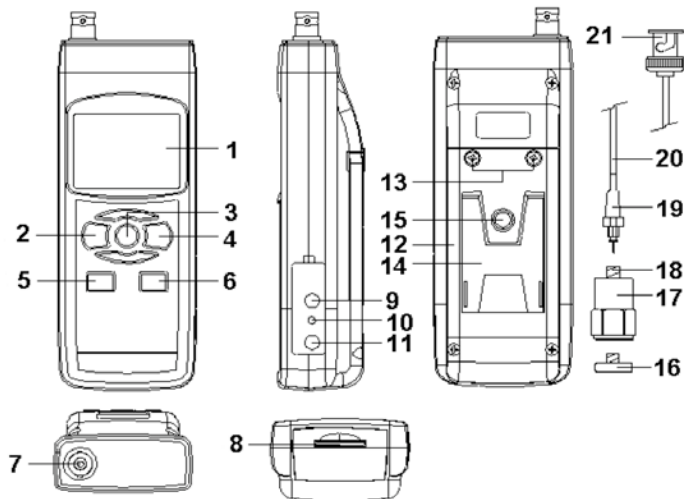

- | | |
|---|-------------------------------|
| 1. Display | 12. Battery Compartment/Cover |
| 2. Power, ESC, & Backlight Button | 13. Battery Cover Screws |
| 3. Hold, Function, & Next Button | 14. Stand |
| 4. REC, Enter, & Unit Button | 15. Tripod Fix Nut |
| 5. SET, Down, & Time Check Button | 16. Magnetic Base |
| 6. Logger, Up, Sampling Time
Check, Zero, & Max Button | 17. Vibration Sensor |
| 7. BNC input socket | 18. Vibration Sensor Socket |
| 8. SD card slot | 19. Mini Cable Plug |
| 9. USB/RS232 Output | 20. Sensor Cable |
| 10. Reset Button | 21. BNC Cable Plug |
| 11. AC/DC 9V Power Adapter Input
Socket | |

Operating Instructions

- 1) Turn on the meter by pressing the Power Button. To turn the meter off, hold the Power Button for over 2 seconds.
- 2) Plug in the BNC Cable into the BNC Socket, and the Mini Cable Plug into the Vibration Sensor Socket.
- 3) If the surface material of measuring article is not ferrous, hold the Vibration Sensor and touch the Sensor to the surface of the measuring article. If the surface material of measuring article is ferrous, connect Magnetic Base to the Vibration sensor. Place the Vibration sensor and Magnetic Base on the surface of measuring article. Do not touch the Sensor Cable when taking measurements.

Changing Unit

To change the measuring unit, press and hold the Unit Button. The display will flash the units m/s^2 , g, mm/s, cm/s, ft/s^2 , inch/s. Release the Unit Button to select the displayed unit. When measuring with an Acceleration Unit, the screen will display “ACC”. When measuring with an Velocity Unit, the screen will display “VEL”. The selected unit will be saved as the default.

Function selection

- 1) The meter has 3 measuring functions to choose from: RMS, Peak, and Max Hold.
- 2) When the meter is on, press and hold the Function Button. The display will flash “RMS”, “Max Hold”, and “Peak”. Release the Function Button to choose the displayed function.
- 3) RMS measures and Root Means Square (RMS) value. Max Hold measures and updates the max. peak value. Peak measures the peak vibration value. For Acceleration and Velocity measurement, always select RMS measurement. The selected function will be saved as the default.

Zero Adjustment

To make precise measurements, the following zero adjustment procedures should be executed:

- 1) Connect the Vibration Sensor to the Meter via the Vibration Sensor Socket.
- 2) Select Acceleration measurement (m/s^2 , g, ft/s^2)
- 3) Keep the vibration sensor motionless. Be sure there is no signal being picked up.
- 4) Press and hold the Logger Button for at least 5 seconds. The screen will display a zero value. The Zero Adjustment can be executed only when the measured value is less than 10 digits.

Max hold reset procedures

Under Max Hold function, press and hold the Logger Button for at least 5 seconds to clear the existing Max hold value.

Data Hold

While taking a measurement, press the Hold Button once and the measured value will hold on the screen, and a HOLD symbol will appear. Press the Hold Button once again will release the data hold function.

Data Record (Max., Min. reading)

The data record function records the maximum and minimum readings. Press the REC Button once to start the Data Record function and a "REC" symbol will appear on the display. With the "REC" symbol on the display:

- 1) Press the REC Button once, and a "REC. MAX." symbol along with the maximum value will appear on the display. To delete the maximum value, press the Hold Button once and the display will show a "REC." symbol only and execute the memory function continuously.
- 2) Press the REC Button again, and a "REC. MIN." symbol along with the minimum value will appear on the display.

continued...

To delete the minimum value, press the Hold Button once, and the display will show a “REC.” symbol only and execute the memory function continuously.

- 3) To exit the memory record function, press the REC button for 2 seconds. The display will revert to the current reading.

Backlight ON/OFF

After powering the meter ON, the LCD Backlight will turn on automatically. While taking measurements, press the Backlight Button and the LCD Backlight will turn off. Press the Backlight Button once again to turn the LCD Backlight back ON.

Datalogger

Preparation Before Executing the Datalogger Function:

- 1) Insert the optional SD card into the SD card socket.
- 2) Before you use an SD card with this meter for the first time, it is recommend to format the SD card. See Advanced Settings section of this manual for instructions.
- 3) If this is the first time the meter is used you need to adjust the clock. See Advanced Settings section of this manual for instructions.
- 4) Now you need to set the decimal format. The numerical data structure downloaded to the SD card is defaulted used the “.” as the decimal, for example “20.6” “1000.53”. But in certain countries the “,” is used as the decimal point, for example “20,6” “1000,53”. See Advanced Settings section of this manual for instructions on how to change the Decimal Character.

Auto Datalogger (Set sampling time ≥ 1 second)

- 1) Start Datalogging; press the REC Button, and the “REC” symbol will appear on the LCD screen, then press the Logger Button, the “REC” symbol will flash while the measuring data and time informa-

continued...

tion is being saved in memory.

To set the sampling time, and to toggle the beeper sound on or off, refer to the Advanced Settings section of this manual.

- 2) Pause the Datalogging; while Datalogging, if press the Logger Button once. While paused, the “REC” symbol will stop flashing. Press the Logger Button again to resume Datalogging, and the “REC” symbol will begin to flash again.
- 3) Stop Datalogging; while the Datalogger function is paused, press the REC Button for 2 seconds. The “REC” symbol will disappear indicating the Datalogging function has stopped.

Manual Datalogger (Set sampling time = 0 seconds)

- 1) Set sampling time is to 0 second; Press the REC Button, and the “REC” symbol will appear on the LCD screen. Press the Logger Button, and the “REC” symbol will flash once and one Beep will sound, at the same time the measuring data along the time information will be saved in memory. The lower Display will show the Position (record) number, which is saved as well.
- 2) To Change the Position Number; press the Down Button and the lower position number will flash on the display. Press the Up or Down Buttons to set the Position Number (1 to 99) to help identify the measurement location. The lower Display will show P x (x = 1 to 99). After the position number is selected, press the Enter Button to confirm.
- 3) Stop Datalogging; press the REC Button for 2 seconds, and the “REC” symbol will disappear indicating the Datalogging function has stopped.

Checking the Time

During normal functions (not Datalogging), press the Time Check Button and the lower LCD display will show the Year, Month/Date, Hour/Minute.

Check Sampling Time Information

During normal functions (not Datalogging), press the Sampling Button and the lower LCD display will show the Sampling Time Information.

SD Card Data Structure

- 1) The first time the SD card is used in the meter, the SD card will generate a folder: VBA01
- 2) The first time you use the Datalogger, in the folder VBA01, a new file name VBA01001.XLS will be created. The Datalogger will use this file until the Data has reached to 30,000 rows. The meter will then will generate a new file with a subsequent number, for example VBA01002.XLS.
- 3) The folder VBA01 can hold 99.XLS files. When that number has been reached, the meter will then will generate a new folder with a subsequent number, for example VBA02. Max number of VBA--folders is 10.

Data Transfer from SD card to Computer (EXCEL Software)

- 1) After Datalogging, remove the SD card from the SD card slot.
- 2) Plug in the SD card into the Computer's SD card slot or insert the SD card into the optional SD card adapter and connect to your Computer. Turn your computer on and a folder will appear on your desktop representing you SD card.
- 3) Open "Microsoft EXCEL". Download the EXCEL files from the SD Card to the computer by opening up the SD folder and selecting the desired EXCEL files, and drag-and-drop them onto your Computer. Open the files with EXCEL (File – Open).
- 4) The EXCEL file will have the following column headers in this order: Place (Position Number), Date (Year/Month/Day), Time (in 24h clock), Value, and Unit.

Advanced Settings

During normal functions (not Datalogging), press and hold the SET Button for 2 seconds to enter the “Advanced Setting” mode. Press the Next Button scroll through eight main functions, shown on the lower display:

- dAtE** Set clock time (Year/Month/Date, Hour/Minute/Second)
- dEC** Set SD card Decimal character
- PoFF** Auto power OFF management
- bEEP** Set beeper sound ON/OFF
- SP-t** Set sampling time (Hour/Minute/Second)
- Sd F** SD memory card Format

While in the “Advanced Setting” function, press the Esc Button to exit and to return to normal functioning.

Set Clock Time

- 1) When the lower display shows “dAtE”, press the Enter Button. Use the Up and Down Buttons to adjust the Year. After the desired value is set, press the Enter Button to adjust the Month, Date, Hour, Minute, and Second values.
- 2) After all the time values have been set the screen will jump to “SD card Decimal character” setting screen. To exit “Advanced Settings”, press the Esc Button.

Note: After the time value is set, the internal clock will run even when the power is off, if the battery is under normal conditions.

Setting the Decimal point on the SD Card

- 1) When the lower display shows “dEC”, use the Up or Down Buttons to toggle between “bASIC” (“.” Decimal Point) or “Euro” (“,” Decimal Point).
- 2) After the Decimal point character has been selected, press the

Enter Button to save the setting as the default. To exit “Advanced Settings”, press the Esc Button.

Auto power OFF management

- 1) When the lower display shows “PoFF”, use the Up or Down Buttons to select the value “yES” (Enable Auto Power Off) or “no” (Disable Auto Power Off).
- 2) After selecting “yES” or “no”, press the Enter Button to save the setting as the default. To exit “Advanced Settings”, press the Esc Button.

Set Beeper Sound ON/OFF

- 1) When the lower display shows “bBEEP”, use the Up or Down Buttons to select “yES” (Beeper Sound is ON) or “no” (Beeper Sound is OFF).
- 2) After selecting “yES” or “no”, press the Enter Button to save the setting as the default. To exit “Advanced Settings”, press the Esc Button.

Set sampling time

- 1) When the lower display shows “SP-t”, use the Up or Down Buttons to adjust the value to either 0, 1, 2, 5, 10, 30,60, 120, 300, 600, 1800, or 3600 seconds.
- 2) After the Sampling value is selected, press the press the Enter Button to save the setting as the default. To exit “Advanced Settings”, press the Esc Button.

SD memory card Format

Please Note: Formatting the SD card erases all data from that SD card.

- 1) When the lower display shows “Sd F”, use the Up or Down Buttons to select “yES” (format the SD card) or “no” (do not format the SD card).
- 2) To format your SD card, select “yES” and press the Enter Button. The Display will show “yES Enter”, to confirm. Press the Enter But-

ton to confirm.

PC Serial Interface

The instrument features an PC output via 3.5 mm terminal. The connector output is a 16 digit data stream which can be utilized to the user's specific application. An USB RS232 lead with the following connection will be required to link the instrument with the PC serial input.

Meter (3.5mm Jack Plug)	PC (9W "D" Connector)
Center Pin	Pin 2
Ground/Shield	Pin 5

The 16 digit data stream will be displayed in the following format:
D15 D14 D13 D12 D11 D10 D9 D8 D7 D6 D5 D4 D3 D2 D1 D0

D0	End Word
D1 to D4	Upper Display reading, D1= LSD, D4= MSB
D5 to D8	D5=? D6=? D7=? D8=?
D9	Decimal Point (DP) for display 0 = No DP, 1 = 1 DP, 2 = 2 DP, 3 = 3 DP
D10	D10 = 0
D11	D11 = 0
D12	D12 = 0
D13	D13 = 0
D14	D14 = 0
D15	Start Word

System Reset

If an error occurs, press the Reset Button with a Pin. If the Reset Button does not fix the error, please send in the unit to our Calibration Lab for repair. E-mail info@reedinstruments.com for more information.

Battery Replacement

- 1) When the left corner of LCD display shows ~~⊠~~, it is necessary to replace the battery
- 2) Loosen the screws of the Battery Cover and remove
- 3) Remove the batteries and replace with Six DC 1.5 V batteries (UM3, AA, Alkaline/heavy duty)
- 4) Make sure the battery cover is properly secured after changing the battery

For service on this or any other REED product or information on other REED products, contact REED Instruments at info@reedinstruments.com

Notes



