



Series RHP-W Wall Mount Humidity/Temperature/Dew Point Transmitter

Specifications - Installation and Operating Instructions



Shown with optional LCD display

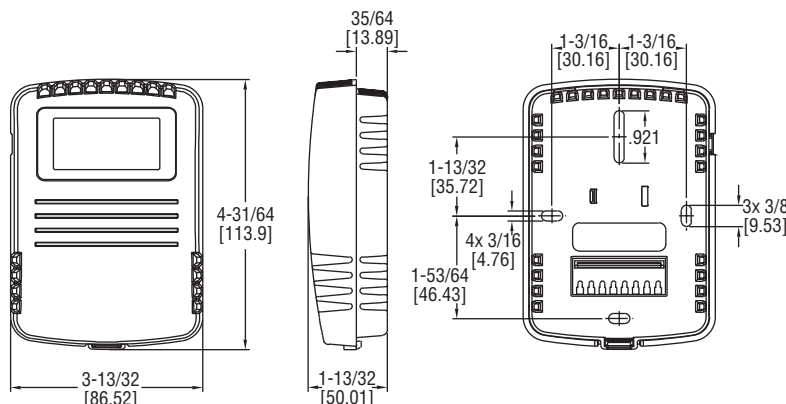

The Series RHP-W Wall Mount Humidity/Temperature/Dew Point Transmitter is the most versatile room transmitter on the market. The stylish housing is well vented to provide air flow across the sensor to improve measurement accuracy. An optional LCD display can be integral to the transmitter or a remote display can be ordered for building balancing or LEED validation. The LCD display indicates the ambient temperature along with the humidity or dew point. The transmitter has internal dip switches to select the temperature engineering units and whether the transmitter outputs humidity or dew point.

The humidity and temperature sensors are field replaceable to reduce service cost and inventory. The humidity and the dew point are measured using a capacitive polymer sensor that completely recovers from 100% saturation. The humidity and dew point can have either a current or voltage output, while the optional temperature output can be a current, voltage, RTD or thermistor. For models with current or voltage for the temperature output, the temperature range is field selectable.

INSTALLATION

WARNING Disconnect power supply before installation to prevent electrical shock and equipment damage.

Make sure all connections are in accordance with the job wiring diagram and in accordance with national and local electrical codes. Use copper conductors only.

CAUTION Use electrostatic discharge precautions (e.g., use of wrist straps) during installation and wiring to prevent equipment damage.

CAUTION Avoid locations where severe shock or vibration, excessive moisture or corrosive fumes are present.

CAUTION Do not exceed ratings of this device, permanent damage not covered by warranty may result. The 4-20 mA models are not designed for AC voltage operation.

SPECIFICATIONS

Relative Humidity Range: 0 to 100% RH.

Temperature Range: -40 to 140°F (-40 to 60°C) for thermistor and RTD sensors. -20 to 140°F (-28.9 to 60°C) for solid state temperature sensors.

Dew Point Temperature Range: -20 to 140°F (-28.9 to 60°C); 0 to 100°F (-17.8 to 37.8°C); 40 to 90°F (4.4 to 32.3°C); -4 to 140°F (-20 to 60°C) field selectable ranges.

Accuracy:

RH: Model RHP2 ±2% 10-90% RH @ 25°C; Model RHP3 ±3% 20-80% RH @ 25°C.

Thermistor Temperature Sensor: ±0.4°F @ 77°F (±0.22°C @ 25°C).

RTD Temperature Sensor: DIN Class B; ±0.54°F @ 32°F (±0.3°C @ 0°C).

Solid State Temperature Sensor: ±0.9°F @ 72°F (±0.3°C @ 25°C).

Hysteresis: ±1%.

Repeatability: ±0.1% typical.

Temperature Limits: -40 to 140°F (-40 to 60°C).

Storage Temperature: -40 to 176°F (-40 to 80°C).

Compensated Temperature Range: -4 to 140°F (-20 to 60°C).

4-20 mA Loop Powered Models:

Power Requirements: 10-35 VDC.

Output Signal: 4-20 mA, 2 channels for humidity/solid state temperature sensor models (loop powered on RH). Switch selectable RH/dew point. Switch selectable normal or reverse output.

0-5/10V Output Models:

Power Requirements: 15-35 VDC or 15-29 VAC.

Output Load: 5 mA max., 2 channels for humidity/solid state temperature sensor models. Switch selectable 0-10V/2-10V or 0-5V/1-5V output. Switch selectable RH/dew point. Switch selectable normal or reverse output.

Solid State Temperature Sensor Output Ranges: Switch selectable, -20 to 140°F (-28.9 to 60°C); 0 to 100°F (-17.8 to 37.8°C); 40 to 90°F (4.4 to 32.3°C); -4 to 140°F (-20 to 60°C).

Response Time: 15 seconds.

Electrical Connections: Screw terminal block.

Drift: <1% RH/year.

RH Sensor: Capacitance polymer.

Enclosure Material: White polycarbonate.

Display: Optional LCD, backlit on 0-5/10V models. Switch selectable %RH or dew point, °F/°C.

Display Resolution: RH: 1%; Temperature: 0.1°F (0.1°C); Dew Point: 1°F (1°C).

Weight: 0.3 lb (0.14 kg).

Agency Approvals: CE.

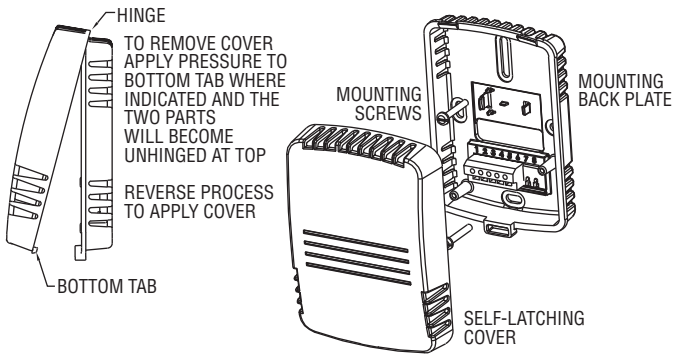

Figure 1

1. Push tab on bottom of cover and lift cover from back plate. (See Figure 1).
2. Select the mounting location, away from diffusers, lights, or any external influences.
3. Mount transmitter on a vertical surface to a standard electrical box using the two #6 M2C type screws provided.
4. Pull wires through sub base hole and make necessary connections.
5. Reattach cover to base plate.

Wiring

Use maximum 18 AWG wire for wiring to terminals. Refer to figures 2 through 5 for wiring information.

Current Output Models (RHP-XW1X)

Current output models must be powered with 10-35 VDC supply voltage. Wire the RH current output as shown in Figure 2. If the unit has a 4-20 mA temperature output, wire the temperature receiver between terminal 3 and the negative terminal of the power supply. If the unit has a passive temperature sensor, wire to terminals 4 and 5. If the RH output is not required, wire the negative terminal of the power supply to terminal 1 of the transmitter. If the temperature output is not used, it may be left disconnected.

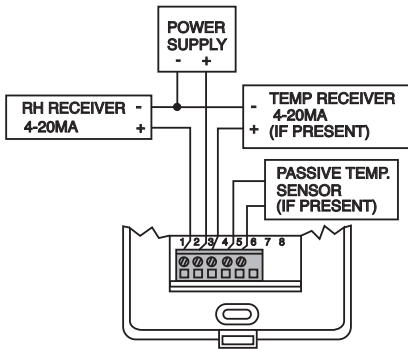

Figure 2

Voltage Output Models (RHP-XW2X)

Wire as shown in Figure 3. Voltage outputs may be powered with 15-35 VDC or 15-29 VAC. Note polarity when using DC power. If the unit has a voltage temperature output, wire the temperature receiver between terminal 4 and negative terminal of power supply. If the unit has a passive temperature sensor, wire to terminals 5 and 6. For units with RH and temperature voltage outputs, the RH or Temperature output may be used by itself.

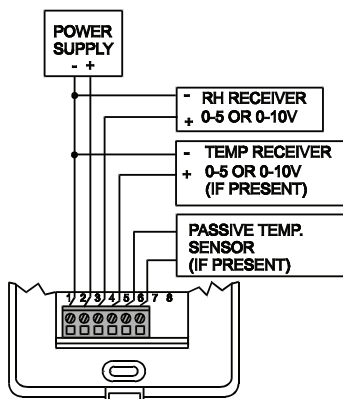

Figure 3

Models with Selectable Current or Voltage Outputs (RHP-XW44)

These models may be wired for current or voltage output. Note that both outputs must be wired either for current or voltage. It is not possible to wire one output for current, and the other for voltage.

Prior to wiring, verify that the Current/Voltage select switch is set to current or voltage as desired. Refer to "Setting the Current/Voltage Select Switch".

Current Output Selected: Wire as shown in Figure 4. Current outputs must be powered with 10-35 VDC. If the RH output is not required, wire the negative terminal of the power supply to terminal 1 of the transmitter. All units come with 4-20 mA RH and Temperature outputs. If the 4-20 mA temperature output is not used it may be left disconnected. If the unit has a passive temperature sensor, wire to terminals 7 and 8.

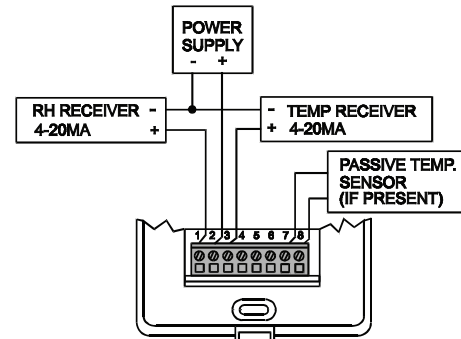

Figure 4

Voltage Output Selected:

Voltage outputs may be powered with 15-35 VDC or 15-29 VAC. Note polarity when using DC power. Wire the RH voltage output as shown in Figure 5. If the unit has a voltage temperature output, wire the temperature receiver between terminal 6 and the negative terminal of the power supply. All units come with RH and Temperature voltage outputs. If the temperature or RH voltage output is not used it may be left disconnected. If the unit has a passive temperature sensor, wire to terminals 7 and 8.

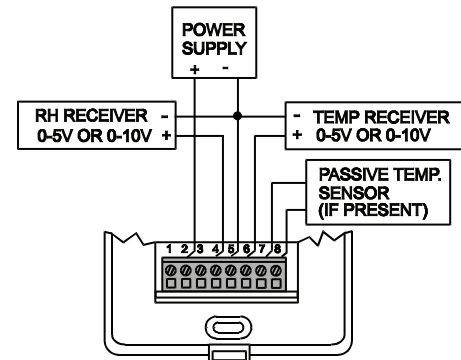

Figure 5

Setting the Current/Voltage Select Switch

Remove the cover of the unit as shown in Figure 1. The Current/Voltage select switch is located on the back of the circuit board. Set the switch "IOUT" for current, "VOUT" for voltage.

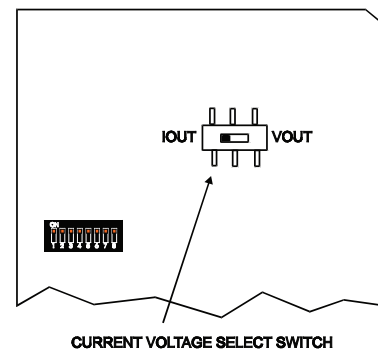

Figure 6

DIP SWITCH SETTINGS

To access the DIP SWITCH, remove the cover of the unit as shown in Figure 1. The DIP SWITCH is located on the back of the circuit board.

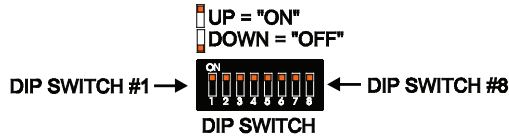

Figure 7

ALL DIP SWITCHES are factory set to "ON"

5V/10V Output Select (Applies only to Voltage Output units)

DIP SWITCH#1 OFF: Output = 0-5V
 DIP SWITCH#1 ON: Output = 0-10V

Zero Suppression (Applies only to Voltage Output Units)

DIP SWITCH#2 OFF : Output range = 1-5V or 2-10V, depending on output range
 DIP SWITCH#2 ON : Output range = 0-5V or 0-10V, depending on output range

Upper Display reads RH or DEW POINT

DIP SWITCH#3 OFF: Upper Display reads Dew Point
 DIP SWITCH#3 ON: Upper Display reads RH

RH OUTPUT, Normal or Invert

DIP SWITCH#4 OFF: Output is inverted
 DIP SWITCH#4 ON: Output is Normal

When set to normal output, the output increases as the RH increases. When set to inverted output, the output decreases as the RH increases.
 Example: Normal 4-20 mA output, 0%RH = 4 mA, 100% RH = 20 mA
 Inverted 4-20 mA output, 0%RH = 20 mA, 100% RH = 4 mA

TEMP OUTPUT, Normal or Invert

DIP SWITCH#5 OFF: Output is inverted
 DIP SWITCH#5 ON: Output is Normal

When set to normal output, the output increases as the temperature increases. When set to inverted output, the output decreases as the temperature increases.
 Example: Normal 4-20 mA output, -20°F = 4 mA, +140°F = 20 mA
 Inverted 4-20 mA output, -20°F = 20 mA, +140°F = 4 mA

°F/°C Select

DIP SWITCH#6 OFF: °C
 DIP SWITCH#6 ON: °F

Temperature Output Range Select

Range	Dip Switch 7	Dip Switch 8
-4 to +140°F (-20 to +60°C)	OFF	OFF
+40 to +90°F (+4.4 to +32.2°C)	OFF	ON
0 to +100°F (-17.8 to +37.8°C)	ON	OFF
-20 to +140°F (-28.9 to +60°C)	ON	ON

The temperature range applies only to the current or voltage output. If the unit has a display, it will display temperature from -40 to +140°F (-40 to +60°C). If the unit is set to read DEW POINT, the output range of the DEW POINT will be the same as the Temperature Output Range.

Note: The display will indicate temperature even if the unit does not have a temperature output.

TROUBLESHOOTING

1. Verify that the unit is mounted in the correct position.
2. **4-20 mA Models:**

Verify appropriate supply voltage. The transmitter requires a minimum of 10 and a maximum of 35 VDC at its connection for proper operation. Choose a power supply with a voltage and current rating which meets this requirement under all operating conditions. If the power supply is unregulated, make sure voltage remains within these limits under all power line conditions. Ripple on the supply should not exceed 100 mV.

Loop Resistance – The maximum allowable loop resistance depends on the power supply voltage. Maximum loop voltage drop must not reduce the transmitter voltage below the 10 VDC minimum. Maximum loop resistance can be calculated with the following equation. V_{ps} is the power supply voltage.

$$R_{max} = \frac{V_{ps} - 10.0}{20 \text{ mA}}$$

Some receivers, particularly loop powered indicators, may maintain a fixed loop voltage to power the device. This voltage drop must also be subtracted from the power supply voltage when calculating the voltage margin for the transmitter. The following equation takes this into account. V_{rec} is the receiver fixed voltage.

$$R_{max} = \frac{V_{ps} - 10.0 - V_{rec}}{20 \text{ mA}}$$

0-10 V Output Models:

Verify appropriate supply voltage. The 0-10V output models require a DC supply of 15 to 35 V or an AC supply of 15-29 V for proper operation maximum. Maximum output load is 5 mA.

FIELD SENSOR REPLACEMENT

Replacement sensors are available. Replacement sensors are factory calibrated and do not require any further calibration.

1. Remove cover as shown in Figure 1.
2. Remove existing sensor as shown in Figure 8.
3. Replace the sensor with appropriate replacement sensor.
4. Reattach cover to base plate.



Figure 8

Remote Display

For models that are ordered without an integral LCD display, remote display Model A-449 can be used to display the temperature and humidity or dew point. The mini USB plug of the remote display plugs into the receptor on the side of the housing. After a short warm up time, the display will begin to show the current temperature and humidity or dew point measurements. Humidity or dew point can be selected via the internal dip switches as described earlier in this manual.

NOTICE Sensor is sensitive to Electro-Static Discharge (ESD). Follow industry standard practice for control and protection against ESD. Failure to exercise good ESD practices may cause damage to the sensor.

MAINTENANCE

Upon final installation of the Series RHP-W Temperature/Humidity/Dew Point Transmitter and the companion receiver, no routine maintenance is required. A periodic check of the system calibration is recommended. Except for sensor replacement, the Series RHP-W is not field serviceable and should be returned if repair is needed (field repair should not be attempted and may void warranty). Be sure to include a brief description of the problem plus any relevant application notes. Contact customer service to receive a return goods authorization number before shipping.

Model Chart

Example	RHP	2	D	1	A	LCD	RHP-2D1A-LCD
Series	RHP						RH/Passive Temperature Sensor Transmitter
Accuracy		2 3					2% Accuracy 3% Accuracy
Housing Type			W				Wall Mount
RH Output				1 2 4			4-20 mA 0-10V/0-5V 0-10V/0-5V/4-20 mA
Temperature Sensor/Output				A B C D E F 0 1 2 4			10K @ 25°C Thermistor Dwyer Curve A 10K @ 25°C Thermistor Dwyer Curve B 3K @ 25°C Thermistor Dwyer Curve C 100Ω RTD DIN 385 1KΩ RTD DIN 385 20KC 25°C Thermistor Curve F NONE 4-20 mA Solid State Sensor 0-10V/0-5V mA Solid State Sensor 0-10V/0-5V/4-20 mA Sensor
Option						LCD Blank	LCD Display No Options

ACCESSORIES

Replacement sensor part number table:

RHP Model #	Replacement Sensor Part #
RHP-2(W)XA	RHPS-D2A
RHP-2(W)XB	RHPS-D2B
RHP-2(W)XC	RHPS-D2C
RHP-2(W)XD	RHPS-D2D
RHP-2(W)XE	RHPS-D2E
RHP-2(W)XF	RHPS-D2F
RHP-2(W)X(0, 1, 2, 4)	RHPS-D20
RHP-3(W)XA	RHPS-D3A
RHP-3(W)XB	RHPS-D3B
RHP-3(W)XC	RHPS-D3C
RHP-3(W)XD	RHPS-D3D
RHP-3(W)XE	RHPS-D3E
RHP-3(W)XF	RHPS-D3F
RHP-3(W)X(0, 1, 2, 4)	RHPS-D30

RESISTANCE VS TEMPERATURE TABLE

Temperature		Resistance Curves (in Ohms)					
°C	°F	A	B	C	D	E	F
-55	-67.0	607800.00	963849.00	289154.70	78.32	783.2	2394000.00
-50	-58.0	441200.00	670166.00	201049.80	80.31	803.1	1646200.00
-45	-49.0	323600.00	471985.00	141595.50	82.29	822.9	1145800.00
-40	-40.0	239700.00	336479.00	100943.70	84.27	842.7	806800.00
-35	-31.0	179200.00	242681.00	72804.30	86.25	862.5	574400.00
-30	-22.0	135200.00	176974.00	53092.20	88.22	882.2	413400.00
-25	-13.0	102900.00	130421.00	39126.30	90.19	901.9	300400.00
-20	-4.0	78910.00	97081.00	29.124.30	92.16	921.6	220600.00
-15	5.0	61020.00	72957.00	21887.10	94.12	941.2	163.500.00
-10	14.0	47540.00	55329.00	16598.70	96.09	960.9	122280.00
-5	23.0	37310.00	42327.00	12698.10	98.04	980.4	92240.00
0	32.0	29490.00	32650.00	9795.00	100.00	1000.0	70160.00
5	41.0	23460.00	25392.00	7617.60	101.95	1019.5	57480.00
10	50.0	18780.00	19901.00	5970.30	103.90	1039.0	41560.00
15	59.0	15130.00	15712.00	4713.60	105.85	1058.5	32340.00
20	68.0	12260.00	12493.00	3747.90	107.79	1077.9	25360.00
25	77.0	10000.00	10000.00	3000.00	109.74	1097.4	20000.00
30	86.0	8194.00	8057.00	2417.10	111.67	1116.7	15892.00
35	95.0	6752.00	6531.00	1959.30	113.61	1136.1	12704.00
40	104.0	5592.00	5326.00	1597.80	115.54	1155.4	10216.00
45	113.0	4655.00	4368.00	1310.40	117.47	1174.7	8264.00
50	122.0	3893.00	3602.00	1080.60	119.40	1194.0	6722.00
55	131.0	3271.00	2986.00	895.80	121.32	1213.2	5498.00
60	140.0	2760.00	2488.00	746.40	123.24	1232.4	4520.00
65	149.0	2339.00	2083.00	624.90	125.16	1251.6	3734.00
70	158.0	1990.00	1752.00	525.60	127.08	1270.8	3100.00
75	167.0	1700.00	1480.00	444.00	128.99	1289.9	2586.00
80	176.0	1458.00	1255.00	376.50	130.90	1309.0	2166.00
85	185.0	1255.00	1070.00	321.00	132.80	1328.0	1822.60
90	194.0	1084.00	915.50	274.65	134.71	1347.1	1540.00
95	203.0	939.30	786.60	235.98	136.61	1366.1	1306.40
100	212.0	816.80	678.60	203.58	138.51	1385.1	1112.60
105	221.0	712.60	587.60	176.28	140.40	1404.0	951.00
110	230.0	623.60	510.60	153.18	142.29	1422.9	815.80
115	239.0	547.30	445.30	133.59	144.18	1441.8	702.20
120	248.0	481.80	389.60	116.88	146.07	1460.7	606.40
125	257.0	425.30	341.90	102.57	147.95	1479.5	525.60
130	266.0	376.40	301.00	90.30	149.83	1498.3	N/A
135	275.0	334.00	265.80	79.74	151.71	1517.1	N/A
140	284.0	297.20	235.30	70.59	153.58	1535.8	N/A
145	293.0	265.10	208.90	62.67	155.46	1554.6	N/A
150	302.0	237.00	186.10	55.83	157.33	1573.3	N/A