

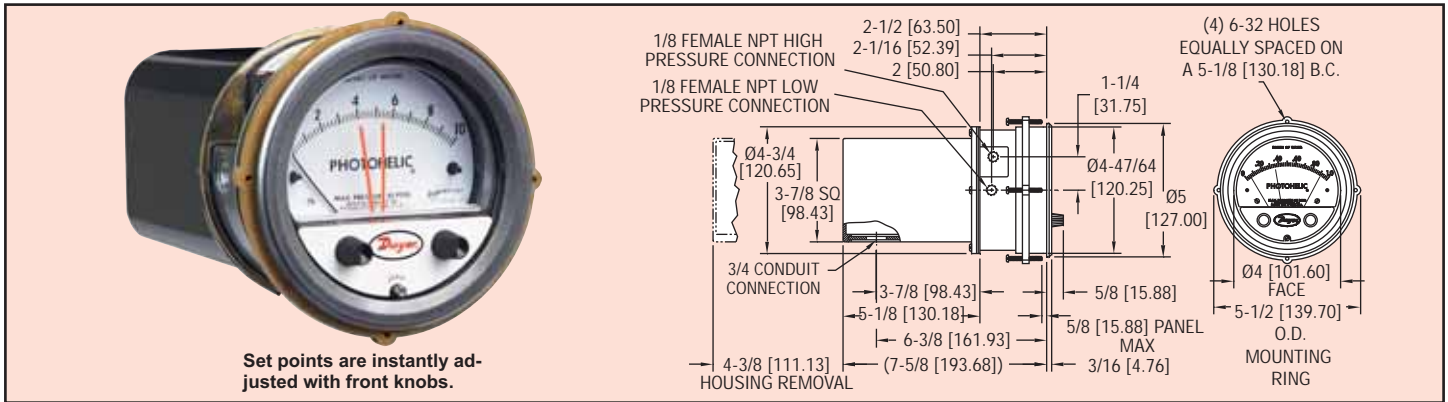

Series  
A3000

# Photohelic® Pressure Switch/Gages

3-in-One Indicating Gage, Lo-Limit and Hi-Limit Control



Set points are instantly adjusted with front knobs.

**Photohelic® Switch/Gages** function as versatile, highly repeatable pressure switches combined with a precise pressure gage employing the time-proven Magnehelic® gage design. The Photohelic® gage measures and controls positive, negative or differential pressures of air and compatible gases. Standard models are rated to 25 psig (1.7 bar) with options to 35 (2.4) or 80 (5.5 bar) psig. Single pressure 36000S models measure to 6000 psig (413 bar) with a 9000 psig (620 bar) rating.

Two phototransistor actuated, DPDT relays are included for low/high limit control. Easy to adjust setpoint indicators are controlled by knobs located on the gage face. Individual setpoint deadband is one pointer width – less than 1% of full scale. Setpoints can be interlocked to provide variable deadband – ideal for control of fans, dampers, etc. Gage reading is continuous and unaffected by switch operation, even during loss of electrical power. Choose from full scale pressure ranges from a low 0-.25" (0.6 mm) w.c. up to 30 psi (21 bar); single positive pressure to 6000 psig (413 bar).

#### Photohelic Sensing - How It Works

In typical applications, these Dwyer switch/gages control between high and low pressure set points. When pressure changes, reaching either set point pressure, the infrared light to the limiting phototransistor is cut off by the helix-driven light shutter. The resulting phototransistor signal is electronically amplified to actuate its DPDT slave relay and switching occurs. Dead band between make and break is 1% of full scale or less — just enough to assure positive, chatter-free operation.

#### Relay - Transformer Features

A plastic housing protects all electronic components. Solid-state and integrated circuit electronics are on glass-epoxy printed circuit boards and self-extinguishing terminal boards.

#### APPLICATIONS - PHOTOHELIC® SWITCH/GAGES

In both series of pressure switch/gages, you get the convenience of a visual indication plus high-low limit switching. For both OEM and in-plant applications, the Photohelic® switch/gage is used to control pressures in air conditioning systems, clean rooms, fluidic and pneumatic control systems, materials handling equipment, alarm or control fume exhaust systems, control pressure in air structures, and monitor respiratory and blood pressures.

#### Standard Model

Two phototransistor-actuated circuits and two DPDT relays permit both high and low alarms or limit controls. Relays are de-energized when gage pointer is to the left of respective set points; relays are energized as pointer passes to the right of set points. Loss of electrical power or loss of pressure provide "fail safe" protection.

#### High and Low Latching Circuits

Dwyer Photohelic® switch/gages can be wired for **high-latching**, **low-latching** or combination **high-low latching** circuits. That is, the equipment will hold in these respective positions once activated and until manually reset. This can be particularly useful for alarm and signal applications where control is accomplished by another Photohelic® switch/gage or other means. Complete wiring and operational instructions are included. Where manual reset is required a dry circuit push button such as Dwyer Part A-601 should be used.

#### SPECIFICATIONS

##### GAGE SPECIFICATIONS

**Service:** Air and non-combustible, compatible gases.

**Wetted Materials:** Consult factory.

**Accuracy:** ±2% of full scale at 70°F (21.1°C). ±3% on -0 and ±4% on -00 models.

**Pressure Limits:** -20" Hg. to 25 psig (-0.677 to 1.72 bar). MP option; 35 psig (2.41 bar), HP option; 80 psig (5.52 bar). A36003S – 36010S; 150 psig (10.34 bar). A36020S and higher; 1.2 x full scale pressure.

**Temperature Limits:** 20 to 120°F (-6.67 to 48.9°C) Low temperature option available.

**Process Connections:** 1/8" female NPT.

**Size:** 4" (101.6 mm) dial face, 5" (127 mm) O.D. x 8-1/4" (209.55 mm).

**Weight:** 4 lb (1.81 kg).

##### SWITCH SPECIFICATIONS

**Switch Type:** Each setpoint has 2 Form C relays (DPDT).

**Repeatability:** ±1% of full scale.

**Electrical Rating:** 10A @ 28 VDC, 10A @ 120, 240 VAC.

**Electrical Connections:** Screw terminals. Use 167°F (75°C) copper conductors only.

**Power Requirements:** 120 VAC, 50/60 Hz; 240 VAC & 24 VAC Power optional.

**Mounting Orientation:** Diaphragm in vertical position. Consult factory for other position orientations.

**Set Point Adjustment:** Adjustable knobs on face.

**Agency Approvals:** UL, CSA, CE. Optional-EXPL Explosion-proof enclosure does not possess any agency approvals.

#### OPTIONS

**Single contact**, right set point, for actuation on increasing or decreasing pressure.

**OEM Model**, less relay and transformer components and housing but including infrared diodes and phototransistor(s), light shutter and set pointer(s). For single or double contact.

**Remote-Mounted Relay**, relay pack may be mounted remotely from gage. Standard

length is 5 ft. For other lengths, specify cable length required.

**Tamper-proof knobs**, low temperature option, special scales, voltages and other features and modifications are available.

**Special Housings** available include Weatherproof (NEMA 4) and Explosion-proof (NEMA 7 CD, 9 EFG; NEC Class I, DIV. 1 & 2, Groups C, D, Class II, Div. 1 & 2, Groups E, F, G, Class III.) Contact Customer Service for detailed dimension drawings.

