

924K

Electronic Preset Counter with two presets

Installation and Operating Instructions



Table of Contents

| | | |
|-----------|---|-----------|
| 1 | Preface | 4 |
| 2 | Safety Instructions and Warnings | 4 |
| 2.1 | Use according to the intended purpose | 4 |
| 2.2 | Mounting in a control panel | 4 |
| 2.3 | Electrical Installation | 4 |
| 3 | Description | 5 |
| 4 | Display/Operating elements | 5 |
| 5 | Inputs | 5 |
| 5.1 | INP A, INP B | 5 |
| 5.2 | RESET | 5 |
| 5.3 | GATE | 5 |
| 5.4 | LOCK INPUT | 5 |
| 5.5 | MPI | 5 |
| 6 | Outputs | 6 |
| 6.1 | Output 1 | 6 |
| 6.2 | Output 2 | 6 |
| 6.3 | Active Outputs | 6 |
| 7 | Programming | 6 |
| 7.1 | Entering the programming | 6 |
| 7.2 | Choice of main menus | 6 |
| 7.3 | Entering a sub-menu | 6 |
| 7.4 | Selecting the menu items | 6 |
| 7.5 | Setting the menu items | 6 |
| 7.6 | Accepting the setting | 6 |
| 7.7 | Ending the programming | 6 |
| 7.8 | Programming Menu | 7 |
| 7.8.1 | Default parameters | 7 |
| 7.8.2 | Table: Parameter Sets | 7 |
| 7.8.3 | Setting the Basic Function | 7 |
| 7.8.4 | Pulse Counter | 8 |
| 7.8.5 | Tacho/Frequency meter | 10 |
| 7.8.6 | Timer | 12 |
| 7.9 | Setting the presets | 16 |
| 7.9.1 | Setting via Decade Keys | 16 |
| 7.9.2 | Setting with Teach-In Function | 16 |
| 7.9.3 | Setting the tracking presets | 16 |
| 7.10 | Set Function | 16 |
| 8 | Error message | 16 |
| 9 | Connections | 17 |
| 9.1 | Signal and Control Inputs | 17 |
| 9.2 | Supply voltage and Outputs | 17 |
| 9.2.1 | Version with relays | 17 |
| 9.2.2 | Version with Optocouplers | 17 |
| 10 | Technical Data | 17 |
| 10.1 | General Data | 17 |
| 10.2 | Pulse counter | 17 |
| 10.3 | Tacho/Frequency meter | 17 |
| 10.4 | Timer | 18 |
| 10.5 | Signal and Control inputs | 18 |
| 10.6 | Outputs | 18 |
| 10.7 | Supply voltage | 18 |
| 10.8 | Sensor supply voltage | 18 |
| 10.9 | Climatic Conditions | 18 |
| 10.10 | EMC | 18 |
| 10.11 | Device safety | 18 |
| 10.12 | Mechanical Data | 18 |
| 10.13 | Connections | 18 |
| 11 | Scope of Delivery | 19 |
| 12 | Ordering codes | 19 |
| 13 | Frequencies (typical) | 20 |
| 13.1 | Pulse counter | 20 |
| 13.2 | Frequency meter | 20 |
| 14 | Input modes: Pulse counting | 21 |
| 15 | Input modes: Timing | 23 |
| 16 | Input modes: Frequency meter | 24 |
| 17 | Output operations | 25 |
| 18 | Dimensional Drawings | 27 |

1 Preface



Please read this instruction manual carefully before installation and start-up. Please observe all warnings and advice, both for your own safety and for general plant safety. If the device is not used in accordance with this instruction manual, then the intended protection can be impaired.

2 Safety Instructions and Warnings



Please use the device only if its technical condition is perfect. It should be used only for its intended purpose. Please bear in mind safety aspects and potential dangers and adhere to the operating instructions at all times.

2.1 Use according to the intended purpose

The preset counter 924 detects and measures pulses, times and frequencies up to max. 60 kHz and offers a wide variety of different operating modes. At the same time, the preset counter processes programmed presets. Use for any purpose over and beyond this will be deemed as not in accordance with its intended purpose and thus not complying with the requirements.

The application area for this device lies in industrial processes and controls, in the fields of manufacturing lines for the metal, wood, plastics, paper, glass, textile and other like industries. Over-voltages at the terminals of the device must be kept within the limits of Over-voltage Category II.

The device must only be operated when mounted in a panel in the correct way and in accordance with the section "Technical Data".

Correct operation of the device requires the mandatory use of the appropriate external safety fuse. Advice concerning the recommended fuse-protection can be found under "Technical Data".

The device is not suitable for use in hazardous areas and for areas excluded in EN 61010 Part 1. If the device is used to monitor machines or processes in which, in the event of a failure of the device or an error made by the operator, there might be the risk of damaging the machine or causing an accident to the operators, then it is your responsibility to take the appropriate safety measures.

2.2 Mounting in a control panel



CAUTION

Mount the device away from heat sources and avoid direct contact with corrosive liquids, hot steam or similar.

Mounting instructions

1. Remove mounting clip from the device.
2. Insert the device from the front into the panel cut-out, ensuring the front-panel gasket is correctly seated.
3. Slide the fixing clip from the rear onto the housing, until the spring clamps are under tension and the upper and lower latching lugs have snapped into place.

2.3 Electrical Installation



DANGER

The device must be disconnected from the power supply, before any installation or maintenance work is carried out. AC-powered devices must only be connected to the low-voltage network via a switch or circuit breaker.

Installation or maintenance work must only be carried out by qualified personnel.

Advice on noise immunity

All connections are protected against external sources of interference. The installation location should be chosen so that inductive or capacitive interference does not affect the device or its connecting lines! Interference (e.g. from switch-mode power supplies, motors, clocked controllers or contactors) can be reduced by means of appropriate cable routing and wiring.

Measures to be taken:

Use only shielded cable for signal and control lines. Connect cable shield at both ends.

The conductor cross-section of the cables should be a minimum of 0.4 mm².

The shield connection to the equipotential bonding should be as short as possible and with a contact area as large as possible (low-impedance).

Only connect the shields to the control panel, if the latter is also earthed.

Install the device as far away as possible from noise-containing cables.

Avoid routing signal or control cables parallel to power lines.

Cables and their insulation should be in accordance with the intended temperature and voltage ranges.

3 Description

6-digit multifunction LCD display
 Easy-to-read 2-line LCD-display with annunciators for both the displayed preset and the status of the two outputs
 Simultaneous display of the actual value and of the presets or auxiliary counters
 Versions with/without backlit display
 Add./Sub. Preset counter with two presets
 Relay or optocoupler outputs
 Easy-to-program
 Simple preset entry via the front keys or via the Teach-In function
 Step or tracking preset
 Pulse, frequency, time or batch counter
 Preset counter, Batch counter or Total Counter (cumulative count)
 Set function for pulse and time counter
 Multiplication and division factor (00.0001 .. 99.9999) for pulse counter and frequency meter
 Averaging and Start Delay for frequency meter
Input modes:
Pulse counter: cnt.dir , up.dn , up.up , quad , quad2 , quad4 , A/B , (A-B)/Ax100%
Frequency meter: A , A - B , A + B , quad , A/B , (A-B)/Ax100%
Timer: FrErUn , Auto , InpA.InpB , InpB.InpB
Output operations:
 Add , Sub , AddAr , SubAr , AddBat , SubBat , AddTot , SubTot , Trail , TrailAr
 4-stage RESET-Mode
 3-stage keypad locking (Lock)
 MPI input for Display Latch, Teach-In function or Set function
 Supply voltage 90 .. 260 VAC or 10 .. 30 VDC

4 Display/Operating elements

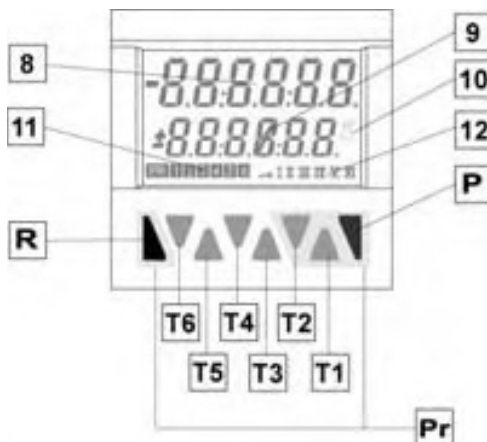

| | |
|------|---|
| T1-6 | Decade key T1 ... T6 |
| P | Prog/Mode key |
| R | Reset key |
| 8 | Current count value / main counter |
| 9 | Preset value/ Total count/ Batch counter |
| 10 | Run display for Timer |
| 11 | Shows which preset value is being displayed |
| 12 | Shows which preset output is active |
| Pr | Keys necessary for programming the parameters (highlighted in grey) |

5 Inputs

5.1 INP A, INP B

Signal inputs: function acc. to operating mode.
 Max. frequency 60 kHz, can be damped in the programming menu to 30 Hz.
 Pulse counter: Count inputs
 Frequency meter: Frequency inputs
 Timer: Start input or Start/Stop inputs

5.2 RESET

Dynamic reset input: resets the pulse counter or timer to zero (adding mode) or to preset value 2 (subtracting mode). The reset input can be inhibited in the programming menu.
 Pulse counter: RESET input
 Frequency meter: no function
 Timer: RESET input

5.3 GATE

Static gate input: function depending on operating mode.
 Pulse counter: no counting while active
 Frequency meter: no counting while active
 Timer: no time measurement while active (Gate.hi)
 no time measurement while not active (Gate.Lo).

5.4 LOCK INPUT

Static keypad lock input for presets or programming. Lock-out level can be set in the programming menu.

5.5 MPI

Input. Programmable as Display Latch, Set or Teach-In input.

6 Outputs

6.1 Output 1

Relay with potential-free make (NO) contact or optocoupler with open emitter and collector



6.2 Output 2

Relay with potential-free make (NO) contact or optocoupler with open emitter and collector.

6.3 Active Outputs

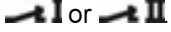
An active output will be shown on the display as



For safety switching the relays or optocoupler outputs can be inverted, i.e. the relay will be de-energized or the optocoupler output disabled when the presets are reached. To do this, the parameters Pr.OUT1 and Pr.OUT2 must be set to  (for permanent signal) or  or  (for timed signal).

7 Programming

7.1 Entering the programming

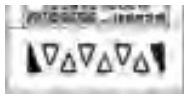

Press the Reset key and Prog/Mode key simultaneously for 3 s

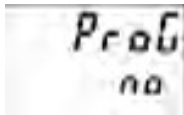

⇒ The security prompt appears in the display

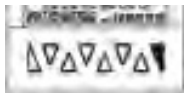

Programming can be exited again using the Prog/Mode key.

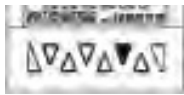

Press key T2 to continue with the programming

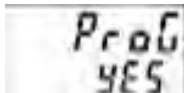

⇒ The security prompt appears in the display

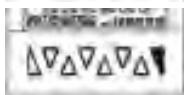

Enter the main menu by pressing the Prog/Mode key

7.2 Choice of main menus

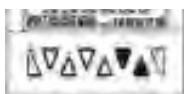

The menus are selected using the keys T2 (next) and T1 (back)

7.3 Entering a sub-menu

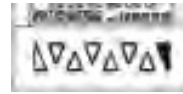

The sub-menu is opened with the Prog/Mode key and the first menu item is displayed.

7.4 Selecting the menu items

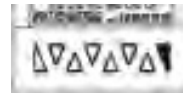

The Prog/Mode key is used to select a menu item within the sub-menu

7.5 Setting the menu items

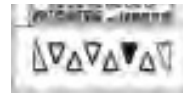

The T2 key is used to select the individual settings for the menu items



When setting count values, each decade has a key assigned to it. Each time the key is pressed, the value increments by one



7.6 Accepting the setting

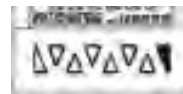

Pressing the Prog/Mode key causes the current setting to be accepted. Programming then switches to the next menu item.

7.7 Ending the programming

During programming, it is possible to exit the programming at each menu item by pressing the reset key.

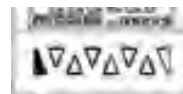

Press the Reset key

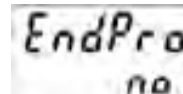

⇒ The security prompt appears in the display

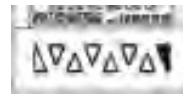

Pressing the Prog/Mode key acknowledges this prompt and causes the programming menu to start again from the beginning. The previously-programmed values are preserved. These can now be changed or checked again.

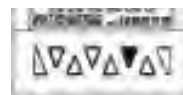

Pressing the decade key T2 selects the termination of the programming

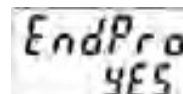

⇒ The security prompt appears in the display



Pressing the Prog/Mode key acknowledges this prompt and terminates the programming; the modified settings are saved in the EEPROM.

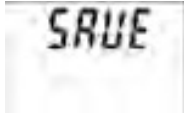

⇒ The text SAVE is displayed for 2 s

7.8 Programming Menu

7.8.1 Default parameters



Note: Three default parameter sets have been permanently stored; these can be adapted as required. With each acknowledgment of the parameter sets, all parameters will be reset to the values listed in the table. The dEFaUL P.USER can be freely programmed.

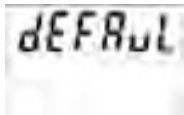

Menu Parameter Sets



Default setting
Parameter set 1

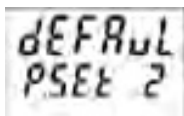

Default setting
Parameter set 2

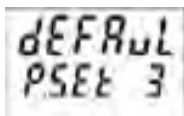

Default setting
Parameter set 3



Freely programmable
User settings



Factory settings are highlighted in grey

7.8.2 Table: Parameter Sets

| | P.SET 1 | P.SET 2 | P.SET 3 |
|-----------------|---------|---------|---------|
| Func | Count | Count | Count |
| InP.PoL | PnP | PnP | PnP |
| FiLteR | on | oFF | oFF |
| Count | Cnt.dir | uP.dn | Quad |
| MPi | LAtch | LAtch | Set |
| Loc.InP | ProG | ProG | ProG |
| ModE | Add | Sub | TrAiL |
| FActor | 01.0000 | 01.0000 | 01.0000 |
| diViSo | 01.0000 | 01.0000 | 01.0000 |
| dP | 0 | 0 | 0.00 |
| SEtPt | 000000 | 000000 | 0000.00 |
| CoLor | red.GrN | red.GrN | red.GrN |
| rESmd | Man.EL | Man.EL | Man.EL |
| PrES 1 | on | on | on |
| Pr.Out 1 | | | |
| t.Out 1 | | 00.10 | |
| Pr.Out 2 | | | |
| t.Out 2 | | 00.10 | 00.10 |

7.8.3 Setting the Basic Function

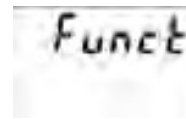

Basic function menu

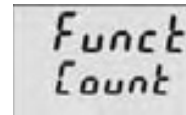

Programming menu
Pulse counter (7.8.4)

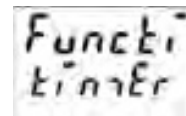

Programming menu
Timer/Hour meter (7.8.6)

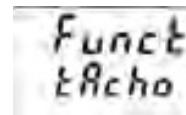

Programming menu
Tacho/Frequency meter (7.8.5)

7.8.4 Pulse Counter

7.8.4.1 Submenu for the Signal and Control inputs

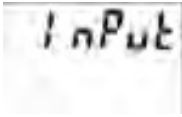

Menu for programming the signal and control inputs

Input polarity

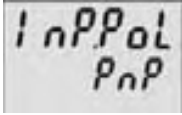

PNP: switching to Plus for all inputs in common



NPN: switching to 0 V for all inputs in common

Filter for the signal inputs InpA and InpB

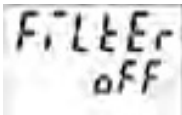

Maximum count frequency

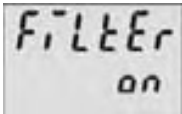

Damped to approx. 30 Hz (for control with mechanical contacts)

Count Input mode

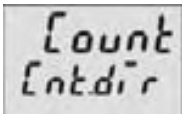

Count/Direction
INP A: count input
INP B: count direction input

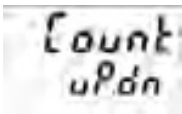

Differential counting [A - B]
INP A: count input add
INP B: count input sub

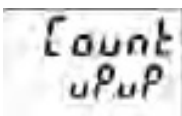

Totalising [A + B]
INP A: count input add
INP B: count input add

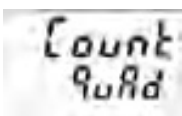

Quadrature input
INP A: count input 0°
INP B: count input 90°

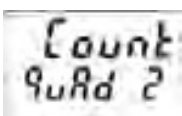

Quadrature with pulse doubling
INP A: count input 0°
INP B: count input 90°
Each pulse edge of INP A will be counted

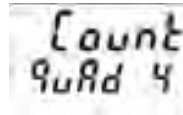

Quadrature x4
INP A: count input 0°
INP B: count input 90°
Each pulse edge of INP A and INP B will be counted.

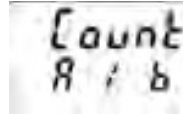

Ratio measurement [A / B]
Inp A: count input A
Inp B: count input B

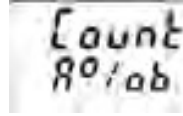

Percentage differential counting
[(A - B) / A in %]
Inp A: count input A
Inp B: count input B

User input

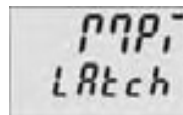

When the MPI input is activated the display is "frozen" and remains "frozen" until the MPI input is deactivated. Internally the preset counter continues counting.

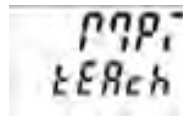

When the MPI input is activated the current count value for the preset that has just been selected will be adopted as the new preset value. See also 7.9

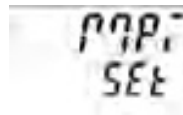

When the MPI input is activated the preset counter will be set to the value specified in the parameter *SEtPt*. See also 7.10

Lock input

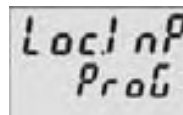

When the Lock input is activated the programming is inhibited.

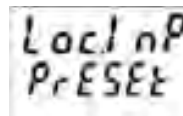

When the Lock input is activated the setting of the preset values is inhibited.

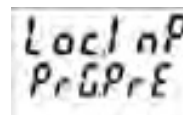

When the Lock input is activated the setting of the preset values and the programming are both inhibited.

7.8.4.2 Submenu for Output operations

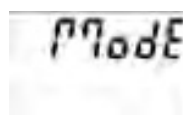

Submenu for determining the operation of the outputs

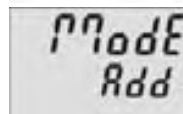

Count mode ADD
Outputs active when count status \geq preset value
Reset to zero

Count mode
Addtot

Count mode SUBTRACT
Output 1 active when
count status \leq preset value 1
Output 2 active when
count status \leq 0
Reset to preset 2

Count mode
AddAr

**Count mode ADDING with
automatic reset**
Output 1 active when count
status \geq preset value 1
Output 2 (timed signal) active
when count status = preset value
2
Automatic reset to zero when
count status = preset value 2
Reset to zero

Count mode
SubAr

**Count mode SUBTRACTING
with automatic reset**
Output 1 active when count
status \leq preset value 1
Output 2 (timed signal) active
when count status = 0
Automatic reset to preset 2 when
count status = 0
Reset to preset 2

Count mode
AddbAr

**Count mode ADDING with
automatic reset and Batch
counter**
Output 2 (timed signal) active
when main counter = preset
value 2
Automatic reset to zero when
main counter = preset 2
Batch counter counts the number
of automatic repetitions of preset
2
Output 1 active when Batch
counter \geq preset 1
Manual reset sets both counters
to zero.
Electrical reset only sets the
main counter to zero.

Count mode
SubbAr

**Count mode SUBTRACTING
with automatic reset and Batch
counter**
Output 2 (timed signal) active
when main counter = zero
Automatic reset to preset 2 when
main counter = zero
Batch counter counts the number
of automatic repetitions of preset
2
Output 1 active when Batch
counter \geq preset 1
Manual reset sets main counter
to preset value 2 , batch counter
to zero
Electrical reset only sets the
main counter to preset value 2

Count mode
Addtot

**Count mode ADDING with
automatic reset and Total
counter**
Output 2 (timed signal) active
when main counter = preset
value 2
Automatic reset to zero when
main counter = preset value 2
Total counter counts all the count
pulses from the main counter
Output 1 active when total
counter \geq preset value 1
Manual Reset sets both counters
to zero
Electrical reset only sets the
main counter to zero

Count mode
Subtot

**Count mode SUBTRACTING
with automatic reset and Total
counter**
Output 2 (timed signal) active
when main counter = zero
Automatic reset to preset value 2
when main counter = zero
Total counter counts (sub from
preset value 1) all count pulses
from main counter
Output 1 active when Total
counter \leq zero
Manual reset sets both counters
to the preset values
Electrical reset sets only main
counter to preset value 2

Count mode
ErArL

Tracking Preset mode
When preset 2 is changed then
preset 1 automatically tracks it.
Reset to zero
Preset 1 relative to preset 2 (see
also section 17. Output
operations)

Count mode
Er-Ar

**Tracking Preset mode with
automatic reset**
When preset 2 is changed then
preset 1 automatically tracks it.
Reset to zero.
Automatic reset to zero when
main counter = preset value 2.
Preset 1 relative to Preset 2
(see also section 17. Output
operations)

7.8.4.3 Submenu for configuration

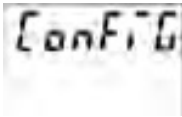

Submenu for matching the input pulses and display

Multiplication factor



Multiplication factor can be programmed from 00.0001 to 99.9999.

The setting 00.0000 will not be accepted

Division factor

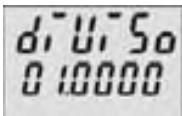

Division factor can be programmed from 01.0000 to 99.9999.

The setting <01.0000 will not be accepted

Decimal point setting

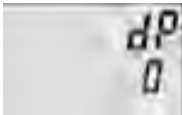

Decimal point (only optical function)

| | |
|---------|------------------|
| 0 | no decimal place |
| 0.0 | 1 decimal place |
| 0.00 | 2 decimal places |
| 0.000 | 3 decimal places |
| 0.0000 | 4 decimal places |
| 0.00000 | 5 decimal places |

Set value



Set value can be programmed from -999999 to 999999

A previously programmed decimal point will be displayed

Display colour (for device 6.92x.x1x3.xx0)

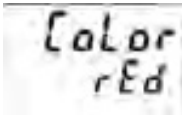

Display colour
upper line red
lower line red

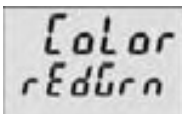

Display colour
upper line red
lower line green

7.8.4.4 Submenu for reset mode

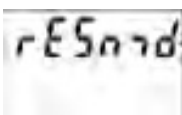

Setting the reset mode

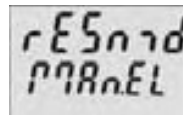

Manual reset (with red key) and electrical reset (reset input)

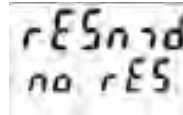

No reset possible (red key and reset input inhibited)

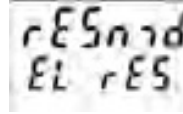

Only electrical reset possible (reset input)

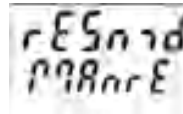

Only manual reset possible (red key)

7.8.4.5 Preset 1

See below 7.8.6.5

7.8.4.6 Preset 2

See below 7.8.6.8

7.8.5 Tacho/Frequency meter

7.8.5.1 Submenu for the Signal and Control inputs

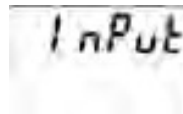

Submenu for programming the signal and control inputs

Input polarity

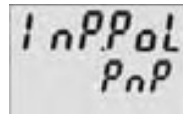

PNP: switching to Plus for all inputs in common

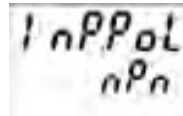

NPN: switching to 0 V for all inputs in common

Filter for the signal inputs Inp A and Inp B

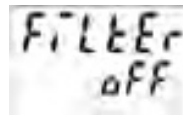

maximum count frequency

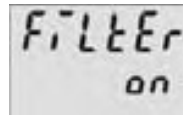

damped to approx. 30 Hz (for control with mechanical contacts)

Input mode Frequency Measurement

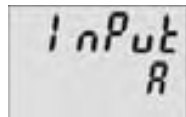

Simple frequency measurement

Inp A: Frequency input
Inp B: no function

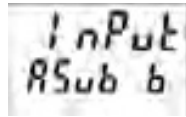

Differential measurement

[A - B]

Inp A: Frequency input A
Inp B: Frequency input B

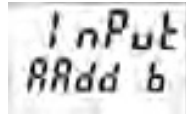

Total measurement [A + B]

Inp A: Frequency input A
Inp B: Frequency input B

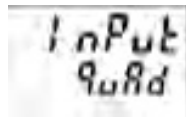

Frequency measurement with direction recognition [Quad]

Inp A: Frequency input 0°
Inp B: Frequency input 90°

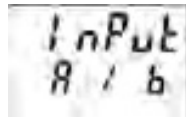

Ratio measurement [A / B]

Inp A: Frequency input A
Inp B: Frequency input B

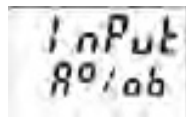

Percentage differential measurement [(A-B) / A in %]

Inp A: Frequency input A
Inp B: Frequency input B

User input



When the MPI input is activated the display is "frozen" and remains "frozen" until the MPI input is deactivated. Internally the frequency meter continues running.

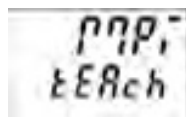

When the MPI input is activated the current frequency for the preset that has just been selected will be adopted as the new preset value. See also 7.9

Lock input

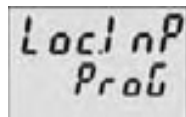

When the Lock input is activated the programming is inhibited.

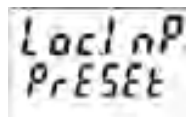

When the Lock input is activated the setting of the preset values is inhibited.

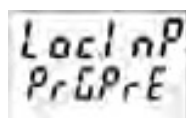

When the Lock input is activated the setting of the preset values and the programming are both inhibited

7.8.5.2 Submenu for configuration

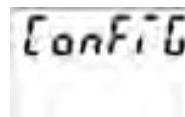

Submenu for matching the input pulses and display

Multiplication factor



Multiplication factor can be programmed from 00.0001 to 99.9999.

The setting 00.0000 will not be accepted

Division factor

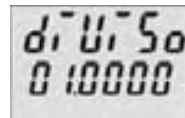

Division factor can be programmed from 01.0000 to 99.9999.

The setting <01.0000 will not be accepted

Display mode

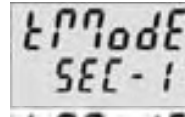

Calculation and display of the frequency / speed in 1/s

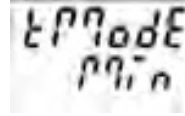

Calculation and display of the frequency / speed in 1/min

Decimal point setting



Decimal point

(determines the resolution)

| | |
|-------|------------------|
| 0 | no decimal place |
| 0.0 | 1 decimal place |
| 0.00 | 2 decimal places |
| 0.000 | 3 decimal places |

Moving average



Moving average calculated

| | |
|--------|----------------------|
| AVG 2 | over 2 measurements |
| AVG 5 | over 5 measurements |
| AVG 10 | over 10 measurements |
| AVG 20 | over 20 measurements |

Start delay

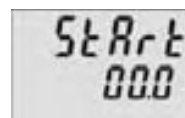

Start delay

Programmable from 00.0 to 99.9 s

At the start of a measurement the measurement results within this time-period are ignored.

Waiting time



Waiting time

Programmable from 00.1 to

99.9 s.

This value specifies how much time should elapse, after the last

valid edge, before zero is to be displayed.

7.8.5.3 Preset 1

See below 7.8.6.5

7.8.5.4 Preset 2

See below 7.8.6.6

7.8.6 Timer

7.8.6.1 Submenu for the Signal and Control inputs

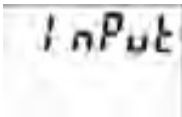

Menu for programming the signal and control inputs

Input polarity

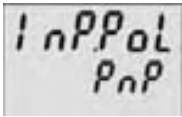

PNP: switching to Plus for all inputs in common

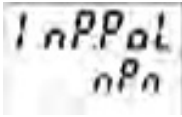

nPn: switching to 0 V for all inputs in common

Filter for the signal inputs Inp A and Inp B

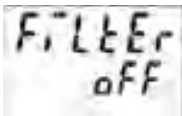

for electronic control of the signal inputs

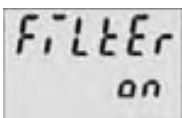

for mechanical control of the signal inputs(for control with mechanical contacts)

Input mode Time measurement

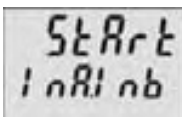

Start: Edge to Inp A
Stop: Edge to Inp B

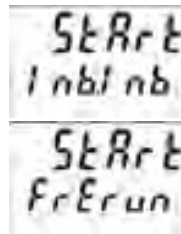

Start: 1. Edge to Inp B
Stop: 2. Edge to Inp B

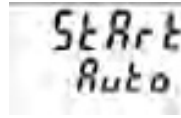

Timing can only be controlled via the Gate input

Inp A and Inp B: no function

The timer is reset by means of a RESET (to zero when adding, to preset 2 when subtracting) and then starts timing again.

Timing is stopped with adding operations when preset 2 is reached.

Timing is stopped with subtracting operations when zero is reached.

A RESET during the timing process also causes this to stop.

Inp A and Inp B: no function.

Gate control for Timing

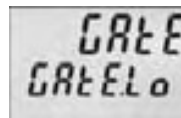

Timing takes place when the Gate input is not active.

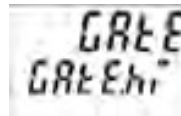

Timing takes place when the Gate input is active

User input

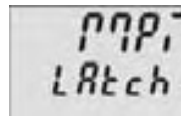

When the MPI input is activated the display is "frozen" and remains "frozen" until the MPI input is deactivated. Internally the preset timer continues counting.

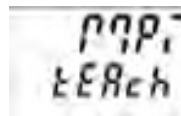

When the MPI input is activated the current count value for the preset that has just been selected will be adopted as the new preset value. See also 7.9

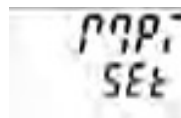

When the MPI input is activated the preset timer will be set to the value specified in the parameter SEtPt. See also 7.10

Lock input

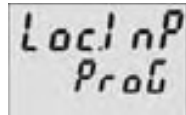

When the Lock input is activated the programming is inhibited.

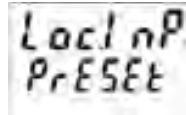

When the Lock input is activated the setting of the preset values is inhibited.

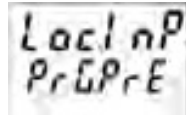

When the Lock input is activated the setting of the preset values and the programming are both inhibited.

7.8.6.2 Submenu for the output operations

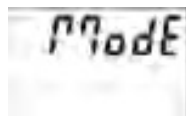

Submenu for determining the operation of the outputs

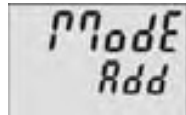

Count mode ADD
Outputs active when count status \geq preset value
Reset to zero

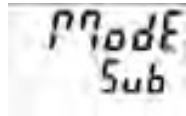

Count mode SUBTRACT
Output 1 active when count status \leq preset value 1
Output 2 active when count status ≤ 0
Reset to preset 2

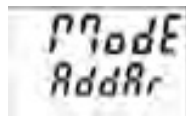

Count mode ADDING with automatic reset
Output 1 active when count status \geq preset value 1
Output 2 (timed signal) active when count status = preset value 2
Automatic reset to zero when count status = preset value 2
Reset to zero

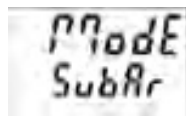

Count mode SUBTRACTING with automatic reset
Output 1 active when count status \leq preset value 1
Output 2 (timed signal) active when count status = 0
Automatic reset to preset 2 when count status = 0
Reset to preset 2

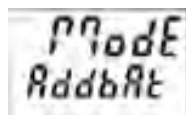

Count mode ADDING with automatic reset and Batch counter
Output 2 (timed output) active when main counter = preset value 2
Automatic reset to zero when

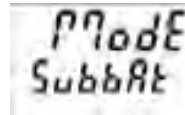

main counter = preset value 2
Batch counter counts the number of automatic repetitions of preset 2
Output 1 active when batch counter \geq preset 1
manual reset sets both counters to zero
electrical reset sets only main counter to zero

Count mode SUBTRACTING with automatic reset and Batch counter

Output 2 (timed signal) active when main counter = zero
Automatic reset to preset 2 when main counter = zero
Batch counter counts the number of automatic repetitions of preset 2
Output 1 active bei Batchzähler \geq Preset 1

Manual reset sets main counters to preset value 2 and batch counter to zero
Electronic reset only sets the main counter to preset value 2

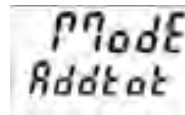

Count mode ADDING with automatic reset and Total counter

Output 2 (timed signal) active when main counter = preset value 2
Automatic reset to zero when main counter = preset value 2
Total counter counts all the count pulses from the main counter
Output 1 active when total counter \geq preset value 1
Manual Reset sets both counters to zero
Electronic reset only sets the main counter to zero

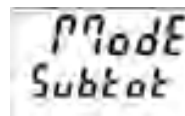

Count mode SUBTRACTING with automatic reset and Total counter

Output 2 (timed signal) active when main counter = zero
Automatic reset to preset value 2 when main counter = zero
Total counter counts (sub from preset value 1) all count pulses from main counter
Output 1 active when Total counter \leq zero
Manual reset sets both counters to the preset values
Electronic reset sets only main counter to preset value 2

Tracking preset mode

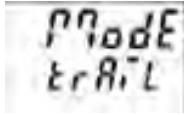

When preset 2 is changed then preset 1 automatically tracks it. Reset to zero

Preset 1 relative to preset 2 (see also section 17. Output operations)

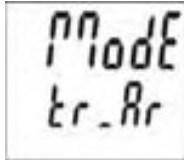

Tracking Preset mode with automatic reset

When preset 2 is changed then preset 1 automatically tracks it. Reset to zero.

Automatic reset to zero when main counter = preset value 2. Preset 1 relative to Preset 2

(see also section 17. Output operations)

7.8.6.3 Submenu for configuration

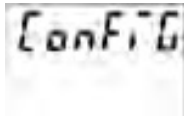

Submenu for matching the time ranges and display

Unit of time

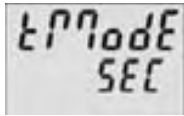

Unit of time: seconds
Decimal point setting determines the resolution

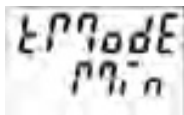

Unit of time: minutes
Decimal point setting determines the resolution

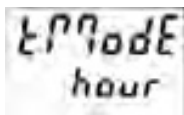

Unit of time: hours
Decimal point setting determines the resolution

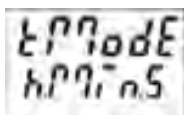

Unit of time: Hrs. Min. Sec.

Decimal point setting (Resolution)

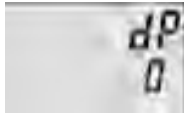

Decimal place (determines the resolution)
0 no decimal place
0.0 1 decimal place
0.00 2 decimal places
0.000 3 decimal places

Set value



Set value can be programmed from 000000 to 999999
A previously programmed decimal point will be displayed

Display colour (for 6.92x.x1x3.xx0]

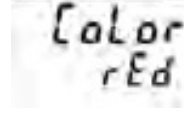

Display colour
upper line red
lower line red

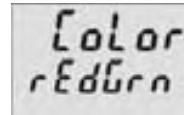

Display colour
upper line red
lower line green

7.8.6.4 Submenu for reset mode

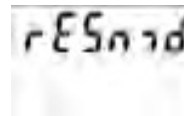

Setting the reset mode

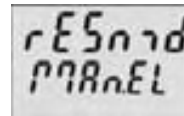

Manual reset (with red key) and electrical reset (reset input)

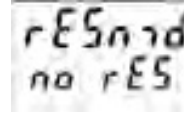

No reset possible (red key and reset input inhibited)

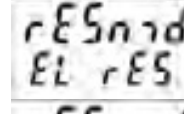

Only electrical reset possible (reset input)

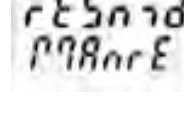

Only manual reset possible (red key)

7.8.6.5 Submenu for Preset 1

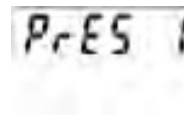

Submenu for turning preset 1 ON/OFF

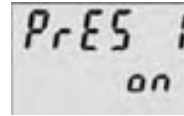

Preset 1 ON

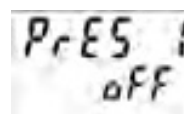

Preset 1 OFF and no function

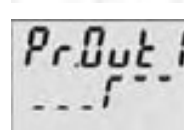

ADD mode output operations: permanent signal at Output 1, becomes active when count \geq Preset 1

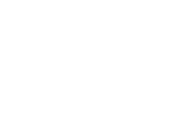

SUB mode output operations: permanent signal at Output 1, becomes active when count \leq Preset 1

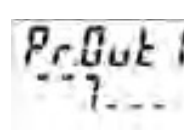

ADD mode output operations: permanent signal at Output 1, becomes passive when count \geq Preset 1

SUB mode output operations:
permanent signal at Output 1,
becomes passive when count \leq
Preset 1

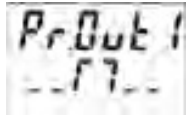

ADD mode output operations:
timed signal at Output 1,
becomes active when count \geq
Preset 1. (Activation only in
positive direction)

SUB mode output operations:
timed output at Output 1,
becomes active when count \leq
Preset 1 (Activation only in
negative direction)

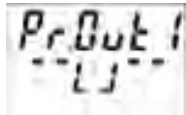

ADD mode output operations:
timed signal at Output 1,
becomes passive when count \geq
Preset 1. (Deactivation only in
positive direction)

SUB mode output operations:
timed output at Output 1,
becomes passive when count \leq
Preset 1. (Deactivation only in
negative direction).

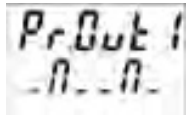

ADD mode output operations:
timed signal at Output 1,
becomes active with positive
direction and when count \geq
Preset 1 and subsequently active
with negative direction and when
count \leq Preset 1

SUB mode output operations:
timed signal at Output 1,
becomes active with negative
direction and when count \leq
Preset 1 and subsequently active
with positive direction and when
count \geq Preset 1

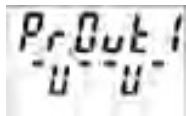

ADD mode output operations:
timed signal at Output 1,
becomes passive with positive
direction and when count \geq
Preset 1 and subsequently
passive with negative direction
and when count \leq Preset 1

SUB mode output operations:
timed output at Output 1,
becomes passive with negative
direction and when count \leq
Preset 1 and subsequently
passive with positive direction
and when count \geq Preset 1

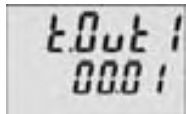

Duration of timed signal of
Output 1, programmable from
00.01 to 99.99 s.

Timed signal is post-triggered

7.8.6.6 Submenu for Preset 2

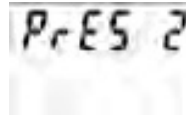

Submenu for Preset 2

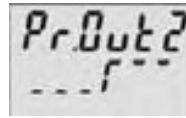

ADD mode output operations:
permanent signal at Output 2,
becomes active when count \geq
Preset 2

SUB mode output operations:
permanent signal at Output 2,
becomes active when count \leq
zero

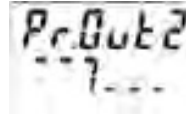

ADD mode output operations:
permanent signal at Output 2,
becomes passive when count \geq
Preset 2

SUB mode output operations:
permanent signal at Output 2,
becomes passive when count \leq
zero

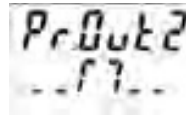

ADD mode output operations:
timed signal at Output 2,
becomes active when count \geq
Preset 2 (Activation only in
positive direction).

SUB mode output operations:
permanent signal at Output 2,
becomes active when count \leq
zero (Activation only in negative
direction)

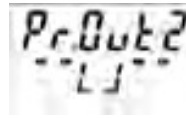

ADD mode output operations:
timed signal at Output 2,
becomes passive when count \geq
Preset 2 (Deactivation only in
positive direction)

SUB mode output operations:
permanent signal at Output 2,
becomes passive when count \leq
zero (Deactivation only in
negative direction).

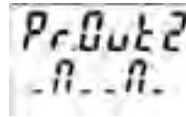

ADD mode output operations:
timed signal at Output 2,
becomes active with positive
direction and when count \geq
Preset 2 and subsequently with
negative direction and when
count \leq Preset 2

SUB mode output operations:
timed signal at Output 2,
becomes active with negative
direction and when count \leq zero
and subsequently with positive
direction and when count \geq zero

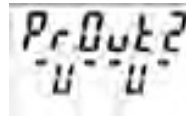

ADD mode output operations:
timed signal at Output 2,
becomes passive with positive
direction and when count \geq

Preset 2 and subsequently with negative direction and when count \leq Preset 2
 SUB mode output operations:
 timed signal at Output 2,
 becomes passive with negative direction and when count \leq zero and subsequently with positive direction and when count \geq zero



Duration of timed signal of Output 1, programmable from 00.01 to 99.99 s.
 Timed output is post-triggered.



Active:
 Relay or optocoupler are activated when the preset value is reached.

Passive:
 Relay becomes de-energized or the optocoupler disabled when the preset value is reached.

7.9 Setting the presets

7.9.1 Setting via Decade Keys

In programming mode Preset 2 will always be displayed in the lower line. This is except for the output operations AddBat, SubBat, AddTot and SubTot.

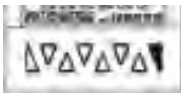

Press the Prog/Mode key until the preset to be changed is displayed - **PR1** or **PR2**.



Press any decade key

⇒ Display switches to the editor mode



Set the desired preset value using the decade keys

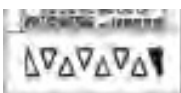

Press the Prog/Mode key to confirm the value and save it

⇒ Display switches to the editor mode of the next preset **PR2** or **PR1**

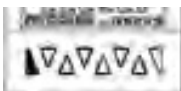

Approx. 3 s after the last press of the decade keys or by pressing the Reset key the new preset value will be accepted and the counter will switch back to operating mode.

7.9.2 Setting with Teach-In Function



Program the MPI input to **tEACH**

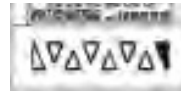

In programming mode, select the preset to be changed using the Prog/Mode key

Briefly activate the MPI (NPN or PNP input logic)

⇒ The current count value will be adopted as the new preset value



The preset value can subsequently be further modified via the decade keypad.

7.9.3 Setting the tracking presets (trail)

If a tracking preset has been programmed, the value for Preset 2 can be set either via the decade keypad or via the Teach-IN function. However the value for Preset 1 must be entered via the decade keypad. In this instance, it is not possible to use the Teach-In function.

7.10 Set Function

Both the pulse counter and the timer can be set to a default value by means of the Set function.

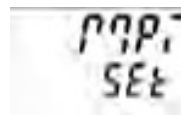

Programme the MPI input to **SEt**

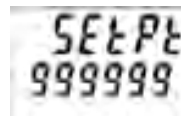

Set menu item **SEtPt** to the desired value

Briefly activate the MPI (NPN or PNP input logic)

⇒ For add. output operations the pulse counter or timer will be set to the **SEtPt** default value

⇒ For sub. output operations the pulse counter or timer will be set to the difference between the value of Preset 2 and the value of **SEtPt**.

8 Error message

| | |
|-------|--|
| Err 1 | Set value is outside the permitted range |
|-------|--|

9 Connections

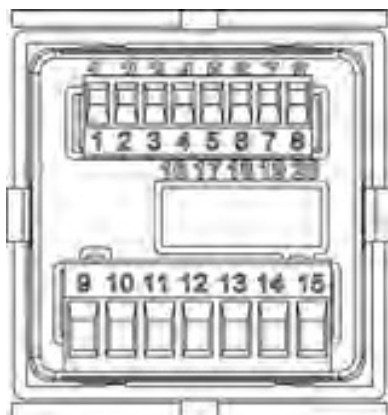

9.1 Signal and Control Inputs

| N° | Designation | Function |
|----|--|--|
| 1 | AC: 24 VDC/80 mA DC: U _B connected through | Sensor supply voltage |
| 2 | GND (0 VDC) | Common connection Signal and Control inputs |
| 3 | INP A | Signal input A |
| 4 | INP B | Signal input B |
| 5 | RESET | Reset input |
| 6 | LOCK | Keypad lock |
| 7 | GATE | Gate input |
| 8 | MPI | User input |

9.2 Supply voltage and Outputs

9.2.1 Version with relays

| N° | Designation | Function |
|----|---------------------------------------|----------------|
| 9 | Relay contact C.1 | Output 1 |
| 10 | Relay contact N.O.1 | |
| 11 | Relay contact C.2 | Output 2 |
| 12 | Relay contact N.O.2 | |
| 13 | Relay contact N.C.2 | |
| 14 | AC: 90..260 VAC N~ DC: 10..30 VDC | Supply voltage |
| 15 | AC: 90..260 VAC L~ DC: GND (0 VDC) | Supply voltage |

9.2.2 Version with Optocouplers

| N° | Designation | Function |
|----|-------------|----------|
|----|-------------|----------|

| N° | Designation | Function |
|----|---------------------------------------|----------------|
| 9 | Collector 1 | Output 1 |
| 10 | Emitter | |
| 11 | Emitter 2 | Output 2 |
| 12 | Not connected | |
| 13 | Collector 2 | Supply voltage |
| 14 | AC: 90..260 VAC N~ DC: 10..30 VDC | |
| 15 | AC: 90..260 VAC L~ DC: GND (0 VDC) | Supply voltage |

10 Technical Data

10.1 General Data

| | | |
|------------------------|---|------|
| Display | LCD positive or negative, backlit | |
| | 2 x 6-digit | |
| Digit height | upper line | 9 mm |
| | lower line | 7 mm |
| | special characters | 2 mm |
| Overload/ Underload | Blinking, 1 s | |
| | Counter loses up to 1 decade no pulses | |
| Data retention | > 10 years, EEPROM | |
| Operation | 8 keys | |

10.2 Pulse counter

Count frequency max. 55 kHz (see section 13. frequencies typ.)

Response time of the outputs:

| | | |
|-----------------------|--|---------|
| Relays | | |
| Add/Sub/Trail | | < 7 ms |
| With automatic repeat | | < 7 ms |
| A/B ; (A-B)/A | | < 29 ms |
| Optocouplers | | |
| Add/Sub/Trail | | < 1 ms |
| With automatic repeat | | < 1 ms |
| A/B ; (A-B)/A | | < 23 ms |

10.3 Tacho/Frequency meter

Frequency range 0,01 Hz to 65 kHz (see section 13. frequencies typ.)

Measuring principle ≤ 76.3 Hz Time interval (period measurement)
 > 76.3 Hz Gate time
 Gate time approx. 13.1 ms

Measuring error < 0.1% per channel

Response time of the outputs:

| | |
|---------------------|-------------------|
| 1-channel operation | < 100 ms @ 40 kHz |
| | < 350 ms @ 65 kHz |
| 2-channel operation | < 150 ms @ 40 kHz |
| | < 600 ms @ 65 kHz |

10.4 Timer

| | |
|-------------------------------|------------------------------------|
| Seconds | 0.001 s ... 999 999 s |
| Minutes | 0.001 min ... 999 999 min |
| Hours | 0.001 h .. 999 999 h |
| h.min.s | 00h.00min.01s ... 99h.59min.59s |
| Min. time measurable | 500µs |
| Measuring error | < 50 ppm |
| Response time of the outputs: | |
| Relays | < 7 ms |
| Optocoupler | < 1 ms |

10.5 Signal and Control inputs

| | |
|---|--|
| Polarity: | programmable NPN/PNP for all inputs in common |
| Input resistance | 5 kΩ |
| Pulse shape | any |
| Switching level with AC supply: | |
| HTL level | Low: 0 ... 4 VDC High: 12 ... 30 VDC |
| 5V level | Low: 0 ... 2VDC High: 3,5 ... 30 VDC |
| Switching level with DC supply: | |
| HTL level | Low: 0 ... 0,2 x UB High: 0,6 x UB ... 30 VDC |
| 5V level | Low: 0 ... 2 VDC High: 3,5 ... 30 VDC |
| Minimum pulse length of the Reset input: | 1 ms |
| Minimum pulse length of the Control inputs: | 10 ms |

10.6 Outputs

Output 1

| | |
|---|------------------------------------|
| Relay with make contact programmable as NC or NO | |
| Switching voltage | max. 250 VAC/ 110 VDC |
| Switching current | max. 3 A AC/ V DC min. 30 mA DC |
| Switching capacity | max. 750 VA / 90 W |
| Mechanical service life (switching cycles) | 2x10 ⁷ |
| N° of switching cycles at 3 A/ 250 V AC | 1x10 ⁵ |
| N° of switching cycles at 3 A/ 30 V DC | 1x10 ⁵ |

| | |
|------------------------------------|--------------|
| or NPN optocoupler | |
| Switching capacity | 30 VDC/10 mA |
| U _{CESAT} for IC = 10 mA: | max. 2.0 V |
| U _{CESAT} for IC = 5 mA: | max. 0.4 V |

Output 2

| | |
|--|------------------------------------|
| Relay with changeover contact | |
| Switching voltage | max. 250 VAC/ 150 VDC |
| Switching current | max. 3 A AC/ A DC min. 30 mA DC |
| Switching capacity | max. 750 VA/ 90 W |
| Mechanical service life (switching cycles) | 20x10 ⁶ |
| N° of switching cycles at 3 A/ 250 V AC | 5x10 ⁴ |
| N° of switching cycles at 3 A/ 30 V DC | 5x10 ⁴ |

| | |
|------------------------------------|---------------|
| or NPN optocoupler | |
| Switching capacity | 30 V DC/10 mA |
| U _{CESAT} for IC = 10 mA: | max. 2.0 V |
| U _{CESAT} for IC = 5 mA: | max. 0.4 V |

10.7 Supply voltage

| | |
|------------|---|
| AC supply: | 90 ... 260 V AC / max. 8 VA 50/ 60 Hz ext. fuse protection: T 0.1 A |
| DC supply: | 10 ... 30 V DC/ max. 1.5 W reverse polarity protection ext. fuse protection T 0.2 A |

10.8 Sensor supply voltage

| | |
|------------|---|
| AC supply: | 24 V DC ±15%, 80 mA |
| DC supply: | max. 80 mA, external voltage supply is connected through |

10.9 Climatic Conditions

| | |
|------------------------|---------------------------------|
| Operating temperature: | -20°C .. +65°C |
| Storage temperature: | -25°C .. +75°C |
| Relative humidity: RH. | 93% at +40°C, non-condensing |
| Altitude: | to 2000 m |

10.10 EMC

| | |
|-----------------|---|
| Noise immunity: | EN61000-6-2 with shielded signal and control cables |
| Noise emission: | EN55011 Class B |

10.11 Device safety

| | |
|-------------------|-----------------|
| Design to: | EN61010 Part 1 |
| Protection Class: | Class 2 |
| Application area: | Soiling Level 2 |

10.12 Mechanical Data

| | |
|---|--|
| Housing: | Panel-mount housing to DIN 43 700, RAL 7021 |
| Dimensions: | 48 x 48 x 91 mm |
| Panel cut-out: | 45 ^{+0,6} x 45 ^{+0,6} mm |
| Installation depth: | ca. 107 mm incl. terminals |
| Weight: | ca. 125 g |
| Protection: | IP 65 (front) |
| Housing material: | Polycarbonate UL94 V-2 |
| Vibration resistance: (EN60068-2-6): | 10 - 55 Hz / 1 mm / XYZ 30 min in each direction |
| Shock resistance (EN60068-2-27): | 100G / XYZ 3 times in each direction |
| Cleaning: | The front of the unit should only be cleaned using a soft damp (water!) cloth. |

10.13 Connections

| | |
|---------------------------------------|--|
| Supply voltage and outputs: | |
| Plug-in screw terminal, 7-pin, RM5.08 | |

Core cross section, max. 2.5 mm²

Signal and control inputs:
Plug-in screw terminal, 8-pin, RM 3.81
Core cross-section, max. 1.5 mm²

11 Scope of Delivery

Delivery includes:

Preset counter
Mounting clip
Instruction manual

12 Ordering codes

Ordering information:

| EXAMPLE | 924K | A | 0 |
|---------------------|------|---|---|
| Series | | | |
| Operating Voltage | | | |
| A = 90 to 260 VAC | | | |
| B = 10 to 30 VDC | | | |
| Outputs | | | |
| 0 = Relay(s) | | | |
| 1 = Opto Coupler(s) | | | |

13 Frequencies (typical)

13.1 Pulse counter

HTL level

| | | |
|---------------|-----------|-------|
| AC supply | typ. Low | 2,5 V |
| | typ. High | 22 V |
| DC supply 12V | typ. Low | 2 V |
| | typ. High | 10 V |
| DC supply 24V | typ. Low | 2,5 V |
| | typ. High | 22 V |

| | Add Sub Trail | AddAr SubAr AddBat SubBat TrailAr | AddTot SubTot |
|----------------|---------------------|---|------------------|
| Cnt.Dir | 55 kHz | 2,8 kHz | 2,7 kHz |
| Up.Dn Up.Up | 29 kHz | 2,8 kHz | 2,7 kHz |
| Quad Quad 2 | 28 kHz | 1,4 kHz | 1,3 kHz |
| Quad 4 | 18 kHz | 1,2 kHz | 0,9 kHz |
| A/B (A-B)/A | 29 kHz | | |

5V level

| | |
|-----------|-------|
| typ. Low | 1,0 V |
| typ. High | 4,0 V |

| | Add Sub Trail | AddAr SubAr AddBat SubBat TrailAr | AddTot SubTot |
|----------------|---------------------|---|------------------|
| Cnt.Dir | 9 kHz | 2,7 kHz | 2,4 kHz |
| Up.Dn Up.Up | 9 kHz | 2,7 kHz | 2,4 kHz |
| Quad Quad 2 | 9 kHz | 1,2 kHz | 1,2 kHz |
| Quad 4 | 9 kHz | 1,2 kHz | 0,9 kHz |
| A/B (A-B)/A | 9 kHz | | |

13.2 Frequency meter

HTL level

| | | |
|---------------|-----------|-------|
| AC supply | typ. Low | 2,5 V |
| | typ. High | 22 V |
| DC supply 12V | typ. Low | 2 V |
| | typ. High | 10 V |
| DC supply 24V | typ. Low | 2,5 V |
| | typ. High | 22 V |

5V level

| | |
|-----------|-------|
| typ. Low | 1,0 V |
| typ. High | 4,0 V |

| | HTL | 5V |
|------------------------------------|--------|-------|
| A | 65 kHz | 9 kHz |
| A – B A + B A / B (A-B)/A | 65 kHz | 9 kHz |
| Quad | 30 kHz | 9 kHz |

NOTE: Switching levels of the input

Switching levels with AC supply:

| | | |
|-----------|-------|---------------|
| HTL level | Low: | 0 .. 4 VDC |
| | High: | 12 .. 30 VDC |
| 5V level | Low: | 0 .. 2VDC |
| | High: | 3,5 .. 30 VDC |

Switching levels with DC supply:

| | | |
|-----------|-------|--------------------|
| HTL level | Low: | 0 .. 0,2 x UB |
| | High: | 0,6 x UB .. 30 VDC |
| 5V level | Low: | 0 .. 2 VDC |
| | High: | 3,5 .. 30 VDC |

14 Input modes: Pulse counting

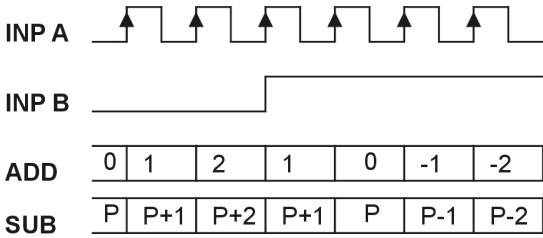
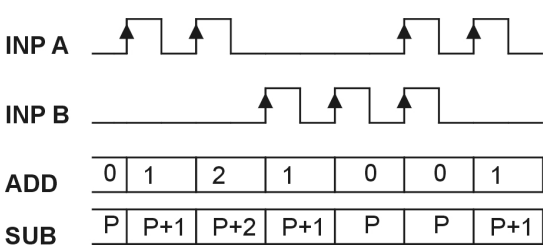
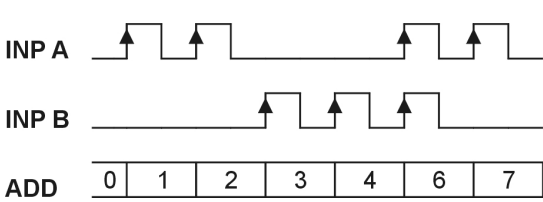
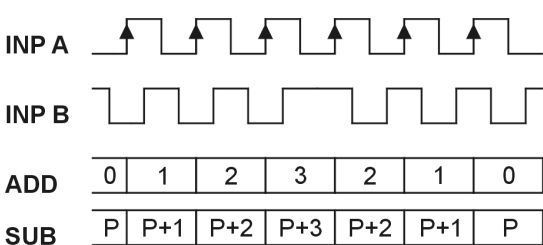
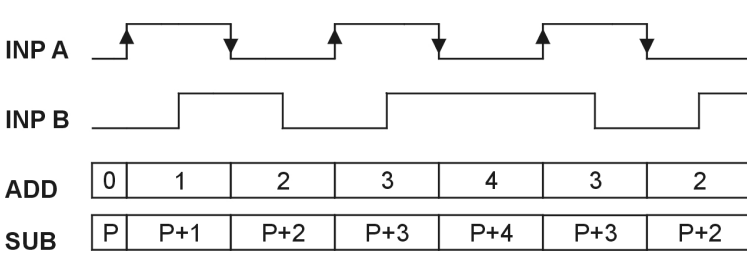
| | | | | | | | | | | | | | | | | |
|----------|--|---|-----|-----|-----|-----|----|----|---|-----|-----|-----|-----|-----|-----|--|
| Function | Diagram Note: No counting when GATE input is active P = Preset | PNP: Count on rising edge NPN: Count on falling edge | | | | | | | | | | | | | | |
| Cnt.Dir |  <p>INP A </p> <p>INP B </p> <p>ADD <table border="1"><tr><td>0</td><td>1</td><td>2</td><td>1</td><td>0</td><td>-1</td><td>-2</td></tr></table></p> <p>SUB <table border="1"><tr><td>P</td><td>P+1</td><td>P+2</td><td>P+1</td><td>P</td><td>P-1</td><td>P-2</td></tr></table></p> | 0 | 1 | 2 | 1 | 0 | -1 | -2 | P | P+1 | P+2 | P+1 | P | P-1 | P-2 | Inp A: Count input Inp B: Count direction Add: Display 0 --> Preset Sub: Display Preset -> 0 |
| 0 | 1 | 2 | 1 | 0 | -1 | -2 | | | | | | | | | | |
| P | P+1 | P+2 | P+1 | P | P-1 | P-2 | | | | | | | | | | |
| Up.Dn |  <p>INP A </p> <p>INP B </p> <p>ADD <table border="1"><tr><td>0</td><td>1</td><td>2</td><td>1</td><td>0</td><td>0</td><td>1</td></tr></table></p> <p>SUB <table border="1"><tr><td>P</td><td>P+1</td><td>P+2</td><td>P+1</td><td>P</td><td>P</td><td>P+1</td></tr></table></p> | 0 | 1 | 2 | 1 | 0 | 0 | 1 | P | P+1 | P+2 | P+1 | P | P | P+1 | Inp A: Count input add Inp B: Count input sub Add: Display 0 --> Preset Sub: Display Preset -> 0 |
| 0 | 1 | 2 | 1 | 0 | 0 | 1 | | | | | | | | | | |
| P | P+1 | P+2 | P+1 | P | P | P+1 | | | | | | | | | | |
| Up.Up |  <p>INP A </p> <p>INP B </p> <p>ADD <table border="1"><tr><td>0</td><td>1</td><td>2</td><td>3</td><td>4</td><td>6</td><td>7</td></tr></table></p> | 0 | 1 | 2 | 3 | 4 | 6 | 7 | Inp A: Count input 1 add Inp B: Count input 2 add Add: Display 0 --> Preset | | | | | | | |
| 0 | 1 | 2 | 3 | 4 | 6 | 7 | | | | | | | | | | |
| Quad |  <p>INP A </p> <p>INP B </p> <p>ADD <table border="1"><tr><td>0</td><td>1</td><td>2</td><td>3</td><td>2</td><td>1</td><td>0</td></tr></table></p> <p>SUB <table border="1"><tr><td>P</td><td>P+1</td><td>P+2</td><td>P+3</td><td>P+2</td><td>P+1</td><td>P</td></tr></table></p> | 0 | 1 | 2 | 3 | 2 | 1 | 0 | P | P+1 | P+2 | P+3 | P+2 | P+1 | P | A 90° B Inp A: Count input Count on one edge Inp B: Reverse direction Add: Display 0 --> Preset Sub: Display Preset -> 0 |
| 0 | 1 | 2 | 3 | 2 | 1 | 0 | | | | | | | | | | |
| P | P+1 | P+2 | P+3 | P+2 | P+1 | P | | | | | | | | | | |
| Quad 2 |  <p>INP A </p> <p>INP B </p> <p>ADD <table border="1"><tr><td>0</td><td>1</td><td>2</td><td>3</td><td>4</td><td>3</td><td>2</td></tr></table></p> <p>SUB <table border="1"><tr><td>P</td><td>P+1</td><td>P+2</td><td>P+3</td><td>P+4</td><td>P+3</td><td>P+2</td></tr></table></p> | 0 | 1 | 2 | 3 | 4 | 3 | 2 | P | P+1 | P+2 | P+3 | P+4 | P+3 | P+2 | A 90° B Inp A: Count input Count on rising and on falling edges Inp B: Reverse direction Add: Display 0 --> Preset Sub: Display Preset -> 0 |
| 0 | 1 | 2 | 3 | 4 | 3 | 2 | | | | | | | | | | |
| P | P+1 | P+2 | P+3 | P+4 | P+3 | P+2 | | | | | | | | | | |

| | | |
|----------|--|--|
| Function | Diagram Note: No counting when GATE input is active | PNP: Count on rising edge NPN: Count on falling edge |
| Quad 4 | | A 90° B Inp A: Count input Count on rising and on falling edges Inp B: Count input Count on rising and on falling edges, Reverse direction Add: Display 0 --> Preset Sub: Display Preset -> 0 |
| A / B | | Inp A: Count input 1 Inp B: Count input 2 Formula: A / B |
| (A-B)/A | | Inp A: Count input 1 Inp B: Count input 2 Formula: $(A - B)/A \times 100$ |





15 Input modes: Timing

| Function | Diagram | PNP: Count on rising edge NPN: Count on falling edge | | | | | | | | | | | | | | | | | | | | | | |
|----------|--|---|-------|---------|-------|-------|------|--|------|-------|---------|--|---|---|------|------|---|------|------|------|---------|---|------|---|
| InA.InB | <p>INP A</p> <p>INP B</p> <p>GATE</p> <p>ADD</p> <table border="1"> <tr> <td>0</td> <td>.....</td> <td>T2</td> </tr> </table> <p>SUB</p> <table border="1"> <tr> <td>P</td> <td>.....</td> <td>P-T2</td> </tr> </table> | 0 | | T2 | P | | P-T2 | Inp A: Start Inp B: Stop Add: Display 0 --> Preset Sub: Display Preset -> 0 | | | | | | | | | | | | | | | | |
| 0 | | T2 | | | | | | | | | | | | | | | | | | | | | | |
| P | | P-T2 | | | | | | | | | | | | | | | | | | | | | | |
| InB.InB | <p>INP B</p> <p>GATE</p> <p>ADD</p> <table border="1"> <tr> <td>0</td> <td>.....</td> <td>T1</td> <td>.....</td> <td>T1+T2</td> </tr> </table> <p>SUB</p> <table border="1"> <tr> <td>P</td> <td>.....</td> <td>P-T1</td> <td>.....</td> <td>P-T1-T2</td> </tr> </table> | 0 | | T1 | | T1+T2 | P | | P-T1 | | P-T1-T2 | Inp A: no function Inp B: Start/Stop Add: Display 0 --> Preset Sub: Display Preset -> 0 | | | | | | | | | | | | |
| 0 | | T1 | | T1+T2 | | | | | | | | | | | | | | | | | | | | |
| P | | P-T1 | | P-T1-T2 | | | | | | | | | | | | | | | | | | | | |
| FrRrun | <p>GATE</p> <p>ADD</p> <table border="1"> <tr> <td>0</td> <td>.....</td> <td>T1</td> <td>.....</td> <td>T1+T2</td> </tr> </table> <p>SUB</p> <table border="1"> <tr> <td>P</td> <td>.....</td> <td>P-T1</td> <td>.....</td> <td>P-T1-T2</td> </tr> </table> | 0 | | T1 | | T1+T2 | P | | P-T1 | | P-T1-T2 | Inp A: no function Inp B: no function Control of the timing only via the GATE input Add: Display 0 --> Preset Sub: Display Preset -> 0 | | | | | | | | | | | | |
| 0 | | T1 | | T1+T2 | | | | | | | | | | | | | | | | | | | | |
| P | | P-T1 | | P-T1-T2 | | | | | | | | | | | | | | | | | | | | |
| Auto | <p>GATE</p> <p>RESET</p> <p>PRESET</p> <p>ADD</p> <table border="1"> <tr> <td>0</td> <td>0</td> <td>....</td> <td>T1</td> <td>0</td> <td>....</td> <td>T2</td> <td>....</td> <td>T2+T3</td> <td>0</td> <td>....</td> </tr> </table> <p>SUB</p> <table border="1"> <tr> <td>P</td> <td>P</td> <td>....</td> <td>P-T1</td> <td>P</td> <td>....</td> <td>P-T2</td> <td>....</td> <td>P-T2-T3</td> <td>P</td> <td>....</td> </tr> </table> | 0 | 0 | | T1 | 0 | | T2 | | T2+T3 | 0 | | P | P | | P-T1 | P | | P-T2 | | P-T2-T3 | P | | Inp A: no function Inp B: no function Control of the timing via RESET (manual or electrical) Add: Display 0 --> Preset Sub: Display Preset -> 0 |
| 0 | 0 | | T1 | 0 | | T2 | | T2+T3 | 0 | | | | | | | | | | | | | | | |
| P | P | | P-T1 | P | | P-T2 | | P-T2-T3 | P | | | | | | | | | | | | | | | |

16 Input modes: Frequency meter

| Function | Diagram | PNP: Count on rising edge NPN: Count on falling edge | | | | | | | | | | | | | | | | | | |
|----------|--|---|-----------------------------------|-----------------------------------|-------------------|-------------------|-------------------|-------------------|---|-----------------|-----------------|-----------------|---|--|---|-----------------|-----------------------------------|-----------------------------------|-------------------|--|
| A | <p>INP A</p> <table border="1"> <tr> <td>0</td> <td>F_{A0}</td> <td>F_{A1}</td> <td>F_{A2}</td> <td>0</td> <td>x</td> </tr> </table> <p>Display</p> <table border="1"> <tr> <td>0</td> <td>0</td> <td>F_{A0}</td> <td>F_{A1}</td> <td>F_{A2}</td> <td>0</td> </tr> </table> | 0 | F _{A0} | F _{A1} | F _{A2} | 0 | x | 0 | 0 | F _{A0} | F _{A1} | F _{A2} | 0 | Inp A: Frequency input Inp B: no function | | | | | | |
| 0 | F _{A0} | F _{A1} | F _{A2} | 0 | x | | | | | | | | | | | | | | | |
| 0 | 0 | F _{A0} | F _{A1} | F _{A2} | 0 | | | | | | | | | | | | | | | |
| AsubB | <p>INP A</p> <table border="1"> <tr> <td>0</td> <td>F_{A0}</td> <td>F_{A1}</td> <td>F_{A2}</td> <td>0</td> <td>x</td> </tr> </table> <p>INP B</p> <table border="1"> <tr> <td>0</td> <td>0</td> <td>F_{B0}</td> <td>F_{B1}</td> <td>F_{B2}</td> <td>x</td> </tr> </table> <p>Display</p> <table border="1"> <tr> <td>0</td> <td>0</td> <td>F_{A0}</td> <td>F_{A0} - F_{B0}</td> <td>F_{A1} - F_{B1}</td> <td>- F_{B2}</td> </tr> </table> | 0 | F _{A0} | F _{A1} | F _{A2} | 0 | x | 0 | 0 | F _{B0} | F _{B1} | F _{B2} | x | 0 | 0 | F _{A0} | F _{A0} - F _{B0} | F _{A1} - F _{B1} | - F _{B2} | Inp A: Frequency input 1 Inp B: Frequency input 2 Formula: A - B |
| 0 | F _{A0} | F _{A1} | F _{A2} | 0 | x | | | | | | | | | | | | | | | |
| 0 | 0 | F _{B0} | F _{B1} | F _{B2} | x | | | | | | | | | | | | | | | |
| 0 | 0 | F _{A0} | F _{A0} - F _{B0} | F _{A1} - F _{B1} | - F _{B2} | | | | | | | | | | | | | | | |
| AaddB | <p>INP A</p> <table border="1"> <tr> <td>0</td> <td>F_{A0}</td> <td>F_{A1}</td> <td>F_{A2}</td> <td>0</td> <td>x</td> </tr> </table> <p>INP B</p> <table border="1"> <tr> <td>0</td> <td>0</td> <td>F_{B0}</td> <td>F_{B1}</td> <td>F_{B2}</td> <td>x</td> </tr> </table> <p>Display</p> <table border="1"> <tr> <td>0</td> <td>0</td> <td>F_{A0}</td> <td>F_{A0} + F_{B0}</td> <td>F_{A1} + F_{B1}</td> <td>F_{B2}</td> </tr> </table> | 0 | F _{A0} | F _{A1} | F _{A2} | 0 | x | 0 | 0 | F _{B0} | F _{B1} | F _{B2} | x | 0 | 0 | F _{A0} | F _{A0} + F _{B0} | F _{A1} + F _{B1} | F _{B2} | Inp A: Frequency input 1 Inp B: Frequency input 2 Formula: A + B |
| 0 | F _{A0} | F _{A1} | F _{A2} | 0 | x | | | | | | | | | | | | | | | |
| 0 | 0 | F _{B0} | F _{B1} | F _{B2} | x | | | | | | | | | | | | | | | |
| 0 | 0 | F _{A0} | F _{A0} + F _{B0} | F _{A1} + F _{B1} | F _{B2} | | | | | | | | | | | | | | | |
| Quad | <p>Inp A</p> <p>Inp B</p> <p>Display</p> <table border="1"> <tr> <td>0</td> <td>0</td> <td>F_{A0}</td> <td>F_{A1}</td> <td>F_{A2}</td> <td>- F_{A3}</td> <td>- F_{A4}</td> </tr> </table> | 0 | 0 | F _{A0} | F _{A1} | F _{A2} | - F _{A3} | - F _{A4} | A 90° B Inp A: Frequency input 1 Inp B: Reverse direction | | | | | | | | | | | |
| 0 | 0 | F _{A0} | F _{A1} | F _{A2} | - F _{A3} | - F _{A4} | | | | | | | | | | | | | | |
| A / B | <p>INP A</p> <table border="1"> <tr> <td>0</td> <td>F_{A0}</td> <td>F_{A1}</td> <td>0</td> <td>0</td> <td>x</td> </tr> </table> <p>INP B</p> <table border="1"> <tr> <td>0</td> <td>0</td> <td>F_{B0}</td> <td>F_{B1}</td> <td>F_{B2}</td> <td>x</td> </tr> </table> <p>Display</p> <table border="1"> <tr> <td>0</td> <td>0</td> <td>0</td> <td>F_{A0}/F_{B0}</td> <td>F_{A1}/F_{B1}</td> <td>0</td> </tr> </table> | 0 | F _{A0} | F _{A1} | 0 | 0 | x | 0 | 0 | F _{B0} | F _{B1} | F _{B2} | x | 0 | 0 | 0 | F _{A0} /F _{B0} | F _{A1} /F _{B1} | 0 | Inp A: Frequency input 1 Inp B: Frequency input 2 Formula: A / B |
| 0 | F _{A0} | F _{A1} | 0 | 0 | x | | | | | | | | | | | | | | | |
| 0 | 0 | F _{B0} | F _{B1} | F _{B2} | x | | | | | | | | | | | | | | | |
| 0 | 0 | 0 | F _{A0} /F _{B0} | F _{A1} /F _{B1} | 0 | | | | | | | | | | | | | | | |
| (A-B)/A | <p>INP A</p> <table border="1"> <tr> <td>0</td> <td>F_{A0}</td> <td>F_{A1}</td> <td>0</td> <td>0</td> <td>x</td> </tr> </table> <p>INP B</p> <table border="1"> <tr> <td>0</td> <td>0</td> <td>F_{B0}</td> <td>F_{B1}</td> <td>F_{B2}</td> <td>x</td> </tr> </table> <p>Display</p> <table border="1"> <tr> <td>0</td> <td>0</td> <td>100%</td> <td>F_{A0}%F_{B0}</td> <td>F_{A1}%F_{B1}</td> <td>0</td> </tr> </table> | 0 | F _{A0} | F _{A1} | 0 | 0 | x | 0 | 0 | F _{B0} | F _{B1} | F _{B2} | x | 0 | 0 | 100% | F _{A0} %F _{B0} | F _{A1} %F _{B1} | 0 | Inp A: Frequency input 1 Inp B: Frequency input 2 Formula: (A - B)/A x100 |
| 0 | F _{A0} | F _{A1} | 0 | 0 | x | | | | | | | | | | | | | | | |
| 0 | 0 | F _{B0} | F _{B1} | F _{B2} | x | | | | | | | | | | | | | | | |
| 0 | 0 | 100% | F _{A0} %F _{B0} | F _{A1} %F _{B1} | 0 | | | | | | | | | | | | | | | |

17 Output operations

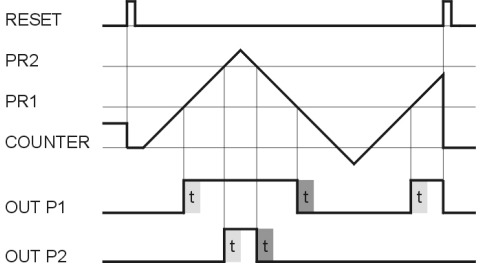
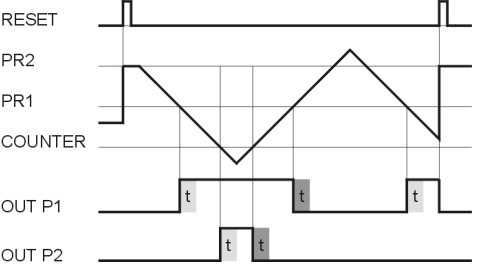
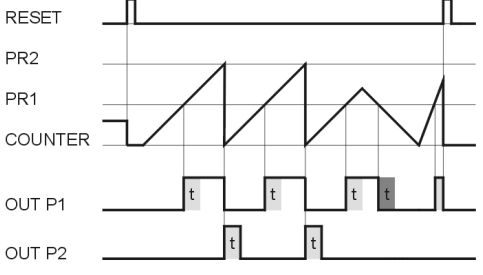
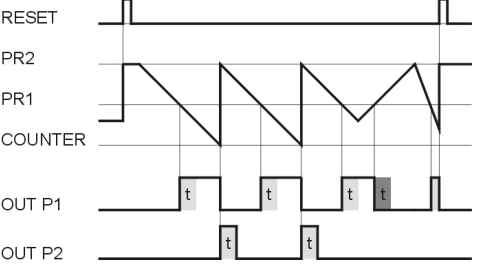
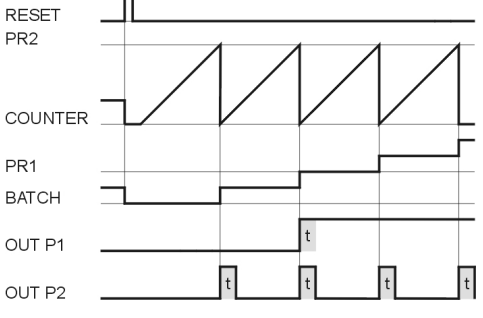
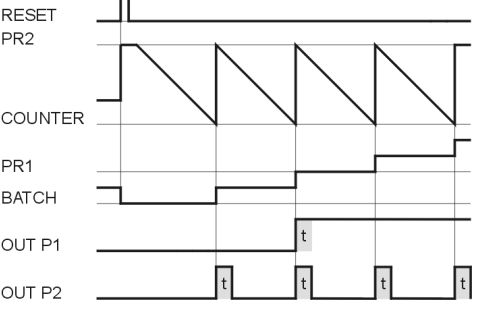
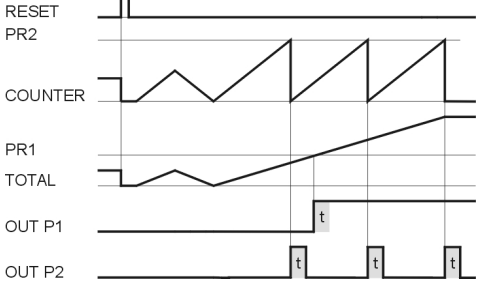
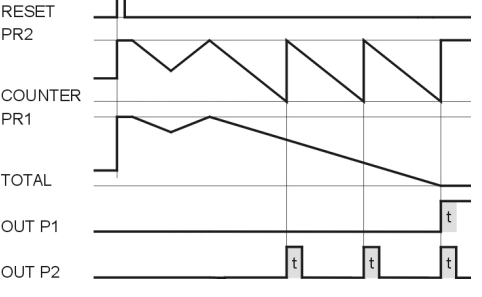
| Mode | Diagram | Mode | Diagram |
|---------------|--|---------------|---|
| | <p>t Only in the mode  and </p> | | <p>t Additionally in the mode  and </p> |
| Add |  | Sub |  |
| AddAr |  | SubAr |  |
| AddBat |  | SubBat |  |
| AddTot |  | SubTot |  |

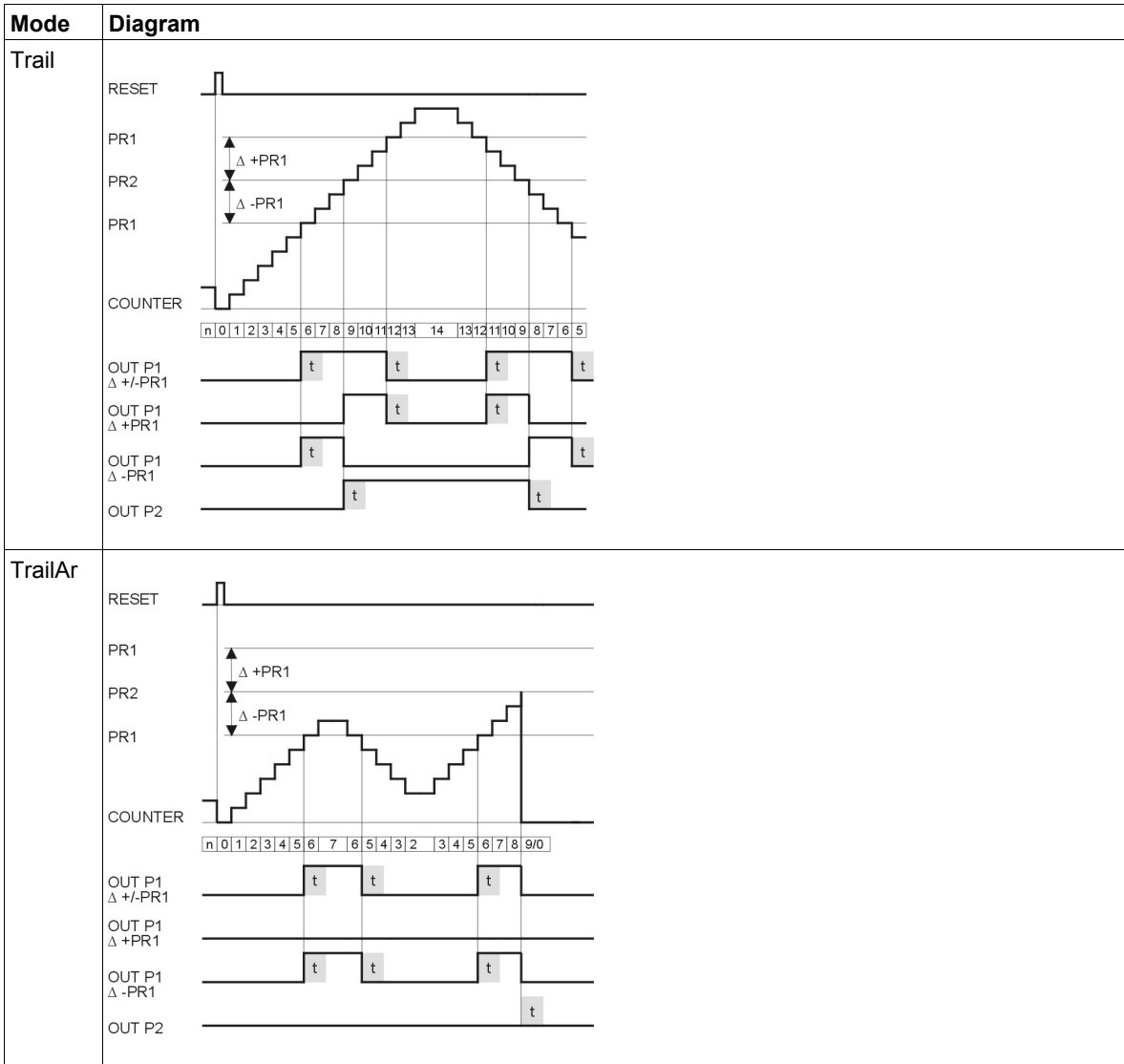

18 Dimensional Drawings

