



Catapult™ 1000

Compact Precision Bench Scales



Rugged design, economical form, and quality.

OHAUS Catapult™ 1000 compact bench scales offer users reliable and precise performance in an affordable, compact design. The Catapult 1000 family offers three capacities, from 20 lb up to 165 lb, reading in pounds and kilograms, with both weighing and dynamic weighing / display hold modes. Catapult 1000 scales are easy to transport and carry with built in carrying handles. Other standard features include an AC power pack, as well as battery operation with power saving auto-shut off mode. OHAUS Catapult 1000 series compact bench scales are the perfect solution for home use, general shipping applications, veterinary weighing, and other dry weighing applications where low cost, portability, and precision are required.

Standard Features Include:

- **Ultra Portable Design** – Catapult 1000 is easy to transport and hold with its light weight, battery operation, and built in handles
- **Durable** – Overload protection is designed into Catapult 1000 weigh cells and makes the scale ideal for tough environments where capacity is exceeded regularly
- **Most Value in its Class** – All Catapult 1000 scales come standard with dynamic weighing mode, auto shutoff, battery or AC power and unparalleled OHAUS durability

Catapult™ 1000 Compact Bench Scales

Specifications

Model	C11P9	C11P20	C11P75
Capacity x Readability	20 x 0.01 lb 9 x 0.005 kg	44 x 0.02 lb 20 x 0.01 kg	165 x 0.1 lb 75 x 0.05 kg
Weighing Units/Modes	lb or kg		
Functions	Weighing, dynamic weighing / display hold		
Keyboard	Two mechanical switches		
Calibration	Digital external span calibration		
Display (H x W)	1 x 2.8 in / 26 x 70 mm, 7 segment 4 digit LCD		
Tare Range	Full capacity by subtraction		
Stabilization Time	<=2 seconds		
Operating Temp. & Humidity	41° F (5° C) to 104° F (40° C) at 10% to 80% relative humidity, non-condensing		
Construction	ABS plastic housing and pan		
Power	AC powered (included) or (3) 'C' batteries (not included)		
Battery Life	300 hours with alkaline cells with auto off after 4 minutes of inactivity		
Dimensions (L x W x H)	10.5 x 12.0 x 2.4 in / 266 x 304 x 60 mm		
Pan Size (L x W)	11.0 x 12.4 in / 280 x 316 mm		
Net Weight	3.5 lbs / 1.5 kg (not including AC adapter)		
Shipping Weight	4.4 lbs / 2kg		

Outline Dimensions

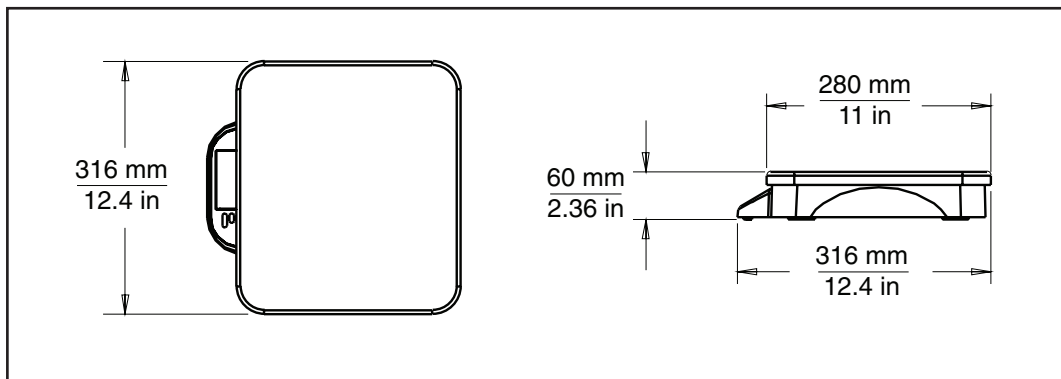

Standard Features

Built in carry handles, large LCD, ABS plastic housing with reinforced ribs, two raised tactile keys, standard AC power adapter or three 'C' cell battery operation (batteries not included), low battery detect, rubber non-slip feet, digital external calibration

Accessories

Stainless steel weighing pan (p/n 80251248)

Compliance

- **Electrical/Emissions:** Meets requirements of approval agencies: UL/CSA (adapter), FCC, CE Safety EN60950, EMC EN61326
Compliant to Directive 2002/96/EC on waste electrical and electronic equipment (WEEE)
- **Quality:** Ohaus quality management system registered to ISO 9001:2008

