



Defender[®] 5000X

Xtreme Rectangular Scales



Counting function is not legal for trade

Smart Functionality, Durability, OHAUS Quality and Value

The OHAUS Defender 5000 Series is a feature-rich line of bench scales, combining a stainless steel D51XW indicator with a rectangular, painted steel base and a painted steel column. Ideal for shipping and receiving, production, packaging and general commercial and industrial weighing applications, the Defender 5000 offers a multifunctional indicator with multiple weighing units and software modes to meet the requirements of industrial and lab applications. With rugged steel construction, comprehensive yet intuitive software and multiple connectivity options, the Defender 5000 can meet the needs of demanding industrial operations.

Standard Features Include:

- All steel construction with stainless steel indicator and painted steel column and base
- 5,000-7,500d default resolution
- NTEP Certified / Measurement Canada Approved resolution up to 1:3,000
- Quick display of results using large LCD with high-contrast white backlight
- Temporary display of 10x readability in weighing mode with quick key press
- Easy to operate with 4-key membrane keypad with raised tactile keys
- Weighs in one or more units: kg, g, lb, oz, lb:oz (decimal), metric tonnes and user-definable custom unit
- Multiple weighing modes including Counting, Percent Weighing, Dynamic/Animal Weighing, Checkweighing, and Display Hold
- Internal universal switching power supply with hardwired line cord – optional NiMH internal rechargeable power pack available
- Includes RS232 interface with GMP/GLP data output including date and time
- Optional interfaces include DC relay control kit, AC relay control kit, 2nd RS232 and RS422/485

Defender[®] 5000X Xtreme Rectangular Scales

The Defender 5000 Offers Multiple Features and Easy Configuration:

To meet different operational needs, the Defender 5000 includes a suite of configurable software:

- Counting mode for packaging and inventory control, enabling counting into a container or out of a container for bulk operations. Supports a maximum counting resolution to 1:300,000 (minimum APW equal to 0.1d), selectable auto-optimization of average piece weight (APW). APW data can be displayed at any time using a quick key press
- Percent Weighing mode for formulation and mixing applications, with display of reference weight with quick key press
- Dynamic/Animal Weighing with selectable weigh times from 0-60 seconds
- Checkweighing function for packaging and weight checking, with display of results using LCD display and red/yellow/green LEDs. Audible beeper can be configured to prompt when weight is within range, under, over, or under or over range. Target weight values can be displayed at any time using a quick key press
- Display Hold mode for weighing large packages holds last stable weight on display until cleared
- The Defender 5000 weighs in one or more user-selectable units: kg, g, lb, oz, lb:oz (decimal), metric tonnes and user-definable custom unit
- Supports GMP/GLP data output with date, time user ID, project ID and scale ID. The Defender 5000 features selectable print options for data and print format
- To limit operator access to functions, the Defender 5000 offers both software lockouts for menu items as well as individual key functions

Outline Dimensions

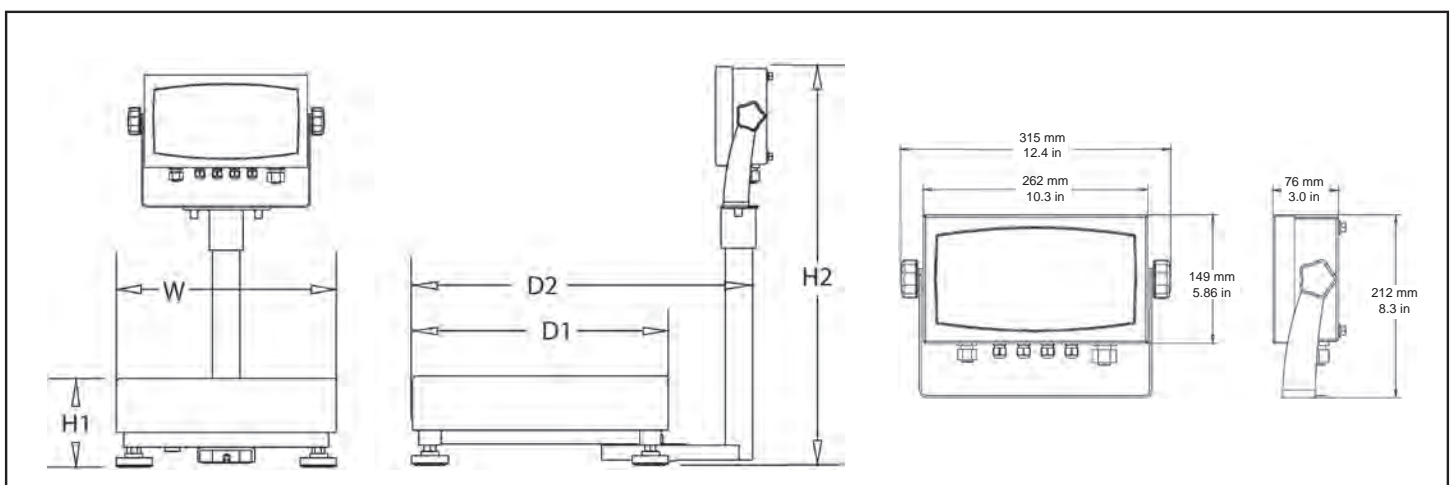

Standard Features:

Optional NiMH Battery
Allows for use in environments where an electrical outlet may not be readily available

3-Color LED Checkweigh
Indication with configurable beeper alert

Included Table/Wall Mount Bracket
With large ergonomic adjustable knobs to maximize viewing angles.

Hinged Front Cover
Only four sealing screws secure the housing for ease of servicing, while still ensuring IP66 seal integrity



Universal Switching Power Supply
Automatically adapts to different voltages and frequencies; plug anywhere, anytime

Durable Base Frame Construction
Stainless steel pans and painted steel form-and-weld frames (R, L bases) provide maximum durability, rigidity and structural integrity. Load-unload cycle tested to ensure long-term performance.



Internal Slot for Capacity Label
Protects label from the effects of moisture and external environments

Stainless Steel 304 NEMA 4X/IP66 Enclosure
Indoor/outdoor protection against falling dirt, rain, sleet, snow, windblown dust, splashing and corrosion

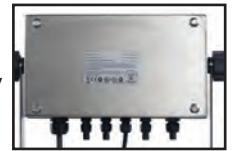

High-Visibility LCD Display
with bright white LED backlight and fast display stable weight within 2 seconds

One-Key, Multiple Mode Selection
Counting, Dynamic Weighing, Display Hold, Percent Weighing and Checkweighing

Stay Connected
Built in RS232 bi-directional interface and external input, optional RS485/422, optional second RS232 and optional AC or DC relay

Painted Steel Columns
Available in both short and tall lengths

Fully Adjustable Feet
Four rugged, adjustable feet help prevent slippage on wet or uneven surfaces

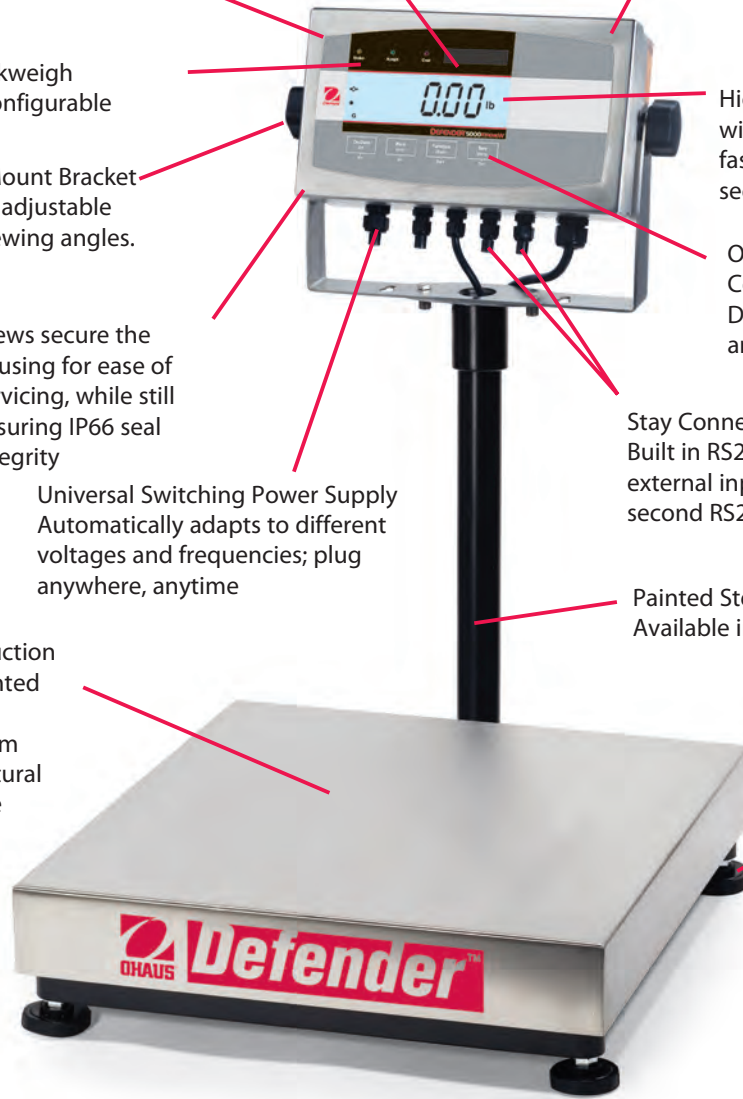

Options and Accessories

Interface Options	OHAUS Number
AC Relay Kit80500720
DC Relay Kit80500727
RS422/485 Interface Kit80500731
Second RS232 Interface Kit80500733
Power Options	
Rechargeable Battery Kit, T51P/T51XW80500729

Other Accessories	OHAUS Number
Compact Dot Matrix Impact Printer80252042
Compact Thermal Printer80251992
OHAUS Collect Software80500746
TAL Software WinWedge80850080
Paper for Printer, 80252042 (1 roll)80251932
Ribbon for Printer, 8025204280251933
RS232 Cable & Adapter, 80252042 Printer to T51XW80252574
RS232 Cable, PC 9 Pin to T51XW80500552
RS232 Cable, PC 25-pin to T51XW80500553

Defender® 5000X Rectangular Scales

Model	D51XW15HR1	D51XW30HR1	D51XW60HR1	D51XW60HL2	D51XW100HL2	D51XW150HX2	D51XW300HX2
Capacity x Default Readability	30lb × 0.002lb 480oz × 0.05oz 30lb : 0.05oz 15kg × 0.001kg 15,000g × 1g	60lb × 0.005lb 960oz × 0.1oz 60lb : 0.1oz 30kg × 0.002kg 30,000g × 2g	150lb × 0.01lb 2,400oz × 0.2oz 150lb : 0.2oz 60kg × 0.005kg 60,000g × 5g		250lb × 0.02lb 4,000oz × 0.5oz 250lb : 0.5oz 100kg × 0.01kg 100,000g × 10g	300lb × 0.02lb 4,800oz × 0.5oz 300lb : 0.5oz 150kg × 0.01kg 150,000g × 10g	600lb × 0.05lb 9,600oz × 1oz 600lb : 1oz 300kg × 0.02kg 300,000g × 20g
Maximum Displayed Resolution	1:15,000	1:12,000	1:15,000		1:12,500	1:15,000	1:12,000
Capacity x Certified/Approved Readability	30 lb × 0.01 lb 15 kg × 0.005 kg	60 lb × 0.02 lb 30 kg × 0.01 kg	150 lb × 0.05 lb 60 kg × 0.02 kg		250 lb × 0.1 lb 100 kg × 0.05 kg	300 lb × 0.1 lb 150 kg × 0.05 kg	600 lb × 0.2 lb 300 kg × 0.1 kg
Maximum Certified Resolution	1:3,000	1:3,000	1:3,000		1:2,500	1:3,000	1:3,000
Indicator Model	T51XW						
Column	13.8 in / 350 mm painted steel			26.8 in / 680 mm painted steel			
Construction	Stainless steel indicator, removable weighing platform, painted steel column and base construction, aluminum loadcell						
Safe Overload Capacity	150% of maximum capacity						
Protection	NEMA 4X/IP66 for indicator, IP67 for loadcell						
Weighing Units	lb, oz, lb:oz, kg, g, metric tonnes, custom unit						
Modes	Static Weighing, Dynamic Weighing, Counting, Checkweighing, Percent Weighing, Display Hold						
Display	1 in / 25 mm high 6-digit, 7-segment bright white backlit LCD						
Keyboard	4-button membrane switch						
Stabilization Time	Within 2 seconds						
Auto-zero Tracking	Off, 0.5, 1 or 3 d						
Zeroing Range	2% or 100% of capacity						
Calibration	Span: 1kg or 1lb to 100% of capacity / 3-point linearity (0 - 50% - 100% fixed)						
Power	100-240 VAC / 50-60Hz internal universal power supply						
Interface	RS232 and external input						
Operating Temperature Range	14°F to 104°F / -10°C to 40°C						
Scale Dimensions (W × H1 × H2 × D1 × D2)	12 × 3.7 × 23.6 × 14 × 18.7 in 305 × 95 × 600 × 355 × 475 mm		15.7 × 4.1 × 37 × 19.7 × 24.4 in 400 × 105 × 940 × 500 × 620 mm		16.5 × 4.9 × 37 × 21.7 × 26.4 in 420 × 125 × 940 × 550 × 670 mm		
Shipping Dimensions (L × W × H)	19.3 × 16.1 × 17.3 in 490 × 410 × 440 mm		29.1 × 27.2 × 9.1 in 740 × 690 × 230 mm		29.5 × 30 × 9.1 in 750 × 710 × 230 mm		
Approx. Net Weight	28.4 lb / 12.9 kg		52.2 lb / 23.7 kg		64.1 lb / 29.1 kg		
Approx. Shipping Weight	33.3 lb / 15.1 kg		59.5 lb / 27 kg		70.7 lb / 32.1 kg		

Features

T51XW: Stainless steel water resistant NEMA 4X / IP66 housing, integral faceplate supports for easy servicing, backlit LCD weight display, checkweighing indication (green, yellow, red), membrane keypad with raised tactile keys, built-in bi-directional RS232 with manual/continuous/interval printing, external tare input, hardware configuration lockout switch, internal switching power supply with hardwired cord.

Other Features

Zero point calibration, calibration test, span or linear calibration, selectable auto-zero tracking range, selectable stability range, selectable averaging level, selectable LCD backlight, selectable auto shutoff, retain zero weight data after power-off, Geo gravity adjustment, selectable key beep, key function lock, menu lock, selectable power-on and calibration unit, battery status display, display of gross/net weight, indication of stability, center of zero, over- and underweight, overload and underload conditions. Configuration menus for PRINT1, PRINT2, COM1, COM2, and I/O.

Compliance

- **Legal for Trade (Made from Certified/Approved weighing components):** NTEP (CC No. 08-039 for indicator; 99-203A3 for bases); Measurement Canada (Approval No. AM-5687 for indicator; AM-5675 for bases)
- **Safety and EMC:** $c_{UL_{us}}$ 2005/95/EC low voltage directive: EN60950-1:2001, FCC Part 15 Class A 2004/108/EC EMC directive: EN61326-1:1997; +A1:1998; +A2:2001; + A3>2003
- **Other:** Compliant to Directive 2002/96/EC on waste electrical and electronic equipment (WEEE)
- **Quality:** Ohaus quality management system registered to ISO 9001:2008

*ISO 9001:2008 Registered Quality Management System

74413_F © Copyright OHAUS Corporation

