



Defender™ D500M

Mechanical Floor Beam Scale



Economical and Simple for General Weighing Needs

The OHAUS Defender™ D500M is a portable mechanical industrial scale designed to meet a variety of applications where simplicity and economy are a must. The D500M features an easy-to-read, dual-side flat beam with a shadow-proof poise, providing quick reading under most lighting conditions. A positive beam lock secures the indicator when the scale is not in use. Counterpoise weights allow for scale capacities of up to 1,000 pounds. The D500M scale utilizes a rugged fabricated steel design and is equipped with durable phenolic wheels for easy maneuverability.

Standard Features Include:

- **Versatile** – Adaptable to in-plant, receiving, commercial and general weighing applications
- **Durable** – Constructed of fabricated carbon steel and designed for accuracy and long life
- **Maneuverable** – Lightweight and easy to maneuver with low resistance, wear-resistant phenolic wheels
- **Legal for Trade** – The D500M is NTEP certified as a legal for trade device in the US

Defender™ D500M Mechanical Beam Scale

Specifications

Model	D500M
Capacity x Readability	1,000 lb x 0.5 lb
NTEP Certified Resolution	1:2,000
Platform size	19.25 x 28.13 in
Beam	Die-cast dual-side flat beam
Base	Fabricated carbon steel
Poise	Shadow-proof positive beam lock
Wheels	4 x 5 in diameter, phenolic
Counterpoise Weights	Total 1,000 lb: 2 x 100 lb, 1 x 200 lb, 1 x 500 lb
Net Weight	113.5 lbs
Shipping Weight	124 lbs
Shipping Dimensions (W x D x H)	50.0 x 31.5 x 7.3 in

Outline Dimensions

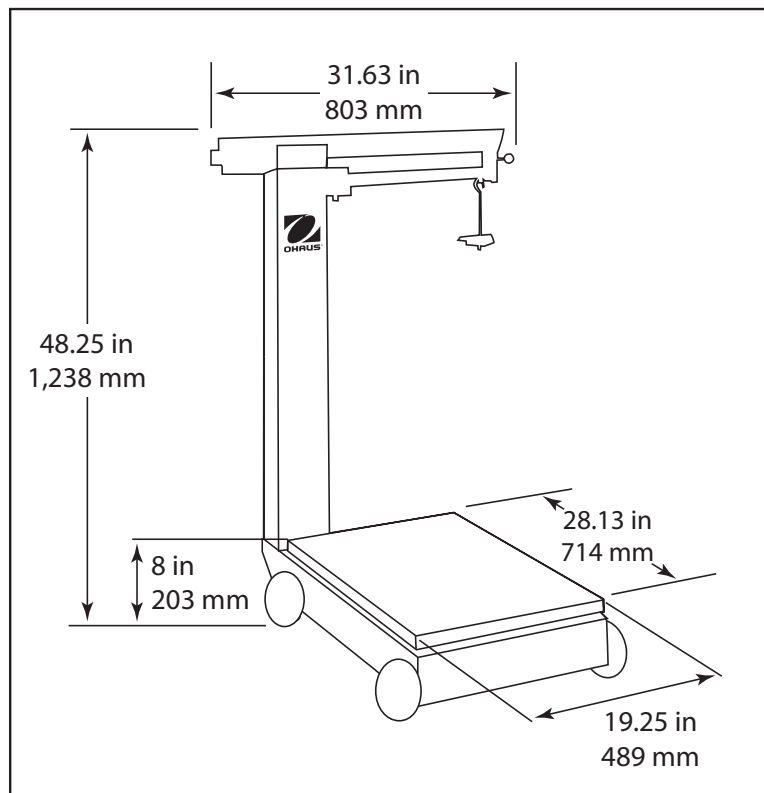

Approvals

NTEP CC No. 08-070

Quality: OHAUS quality management system registered to ISO 9001:2008

OHAUS CORPORATION

8077467_B © Copyright Ohaus Corporation

