



IPAQ C530/R530

Smart 2-wire universal transmitter
with HART[®] 7 and NFC technology

The documentation is only complete when used in combination with the relevant documentation for the signal converter. The manual/handbook must be read prior to adjustment and/or installation. All information is subject to change without notice.

© INOR 07/2024 - 400452/701 - MA IPAQ 530 R04 00

INOR

Find Quality Products Online at:

www.GlobalTestSupply.com

sales@GlobalTestSupply.com

1	Safety instructions	5
1.1	Intended use	5
1.2	Certifications	6
1.2.1	EU directive compliance	6
1.2.2	Ex approvals	6
1.3	Safety instructions from the manufacturer	7
1.3.1	Copyright and data protection	7
1.3.2	Disclaimer	7
1.3.3	Product liability and warranty	8
1.3.4	Information concerning the documentation	8
1.3.5	Warnings and symbols used	9
1.4	Safety instructions for the operator	9
2	Device description	10
2.1	General description	10
2.2	Nameplate	11
2.3	Versioning per NAMUR NE53	12
2.4	Scope of delivery	12
3	Installation	13
3.1	In-head transmitter	13
3.2	Rail mounting kit for in-head transmitters	14
3.3	Rail-mount transmitter	15
4	Electrical connections	16
4.1	Safety instructions	16
4.2	Electrical connections of in-head transmitter	18
4.3	Connection diagram of in-head transmitter	19
4.4	Connection diagram of in-head transmitter (intrinsically safe)	20
4.5	Electrical connections of rail-mount transmitter	21
4.6	Connection diagram of rail-mount transmitter	22
4.7	Connection diagram of rail-mount transmitter (intrinsically safe)	22
4.8	Cable length	23
5	Operation	24
5.1	NFC configuration and logging	24
5.2	HART® networks	25
5.3	Point-to-point connection analog / digital mode	25
5.4	Multi-drop connection	26
5.5	Factory settings for configuration	27
5.6	Configuration with ConSoft	28
5.7	Configuration with a hand held communicator FC 475	32
5.8	Device management software	32

5.9 Configuration with PACTware	33
5.10 Current output and HART [®] dynamic/device variables	33
5.11 Diagnostic information according to NAMUR NE 107	34
5.12 Factory default settings.....	38
5.13 Sensor error monitoring	38
5.14 System or sensor error correction	38
6 Service	39
<hr/>	
6.1 Accessory parts	39
6.2 Spare parts availability.....	39
6.3 Availability of services	39
6.4 Returning the device to the manufacturer.....	39
6.4.1 General information.....	39
6.4.2 Form (for copying) to accompany a returned device.....	41
6.5 Disposal	41
6.5.1 Dispose of the transmitter.....	41
6.5.2 Disassembling and recycling.....	42
6.5.3 Disassembling and recycling of IPAQ C530/C530X	42
6.5.4 Disassembling and recycling of IPAQ R530/R530X	43
6.5.5 Packaging of IPAQ C530/C530X and R530/R530X	45
7 Technical data	46
<hr/>	
7.1 Measuring principles.....	46
7.1.1 Resistance temperature sensor	46
7.1.2 Thermocouples	47
7.2 Technical data.....	48
7.3 Dimensions	53
7.4 Temperature data for areas with potentially explosive atmospheres	54
7.5 Output load diagram.....	55
7.6 Electrical data for outputs and inputs.....	56
7.7 RTD and T/C accuracy table	57
8 Appendix	59
<hr/>	
8.1 Installation and control drawing	59
9 Notes	61
<hr/>	

1.1 Intended use

The IPAQ 530 is a universal HART[®] compatible 2-wire transmitter intended to be used in industrial environments and designed for measurements of:

- Temperature measurements with resistance thermometers
- Temperature measurements with thermocouples
- Voltage measurements in a range up to 1000 mV
- Resistance measurement up to 10 k Ω
- Measurements with potentiometers

C530 / C530X is intended for installation in a DIN B-head or larger according to EN 50446.
R530 / R530X is intended for installation on a 35 mm DIN-rail according to EN 60715.

The transmitters are configured from a PC by using the ConSoft software and a transmitter configuration kit (USB connection), by a HART[®] configurator, by a HART[®] modem and a suitable software, e.g. PactWare, or by a smartphone with built-in NFC support.



DANGER!

You may only use transmitters labelled with the "Ex" symbol in potentially explosive areas or connect them to a sensor located in those areas. Additionally always note the zone(s) for which the devices have an approval. Otherwise the transmitters might cause an explosion that can result in fatal injuries.



DANGER!

Responsibility for the correct use of the devices with special regard to suitability, intended use and the field of application lies solely with the operator. To avoid any kind of incorrect use, also note the information in the chapter "Device description".



DANGER!

The transmitters do not contain any serviceable parts inside. Always send defective devices to the manufacturer or the local distributor for repair or exchange. If this is the case, attach a clear description of the malfunction for warranty claims.



The manufacturer is not liable for any damage resulting from improper use or use for other than the intended purpose. To avoid any kind of incorrect use, also note the information in the chapter "Device description".



CAUTION!

Responsibility for the use of the measuring devices with regard to suitability, intended use and corrosion resistance of the used materials against the measured fluid lies solely with the operator.



CAUTION!

This device is a Group 1, Class A device as specified within CISPR11. It is intended for use in industrial environment. There may be potential difficulties in ensuring electromagnetic compatibility in other environments, due to conducted as well as radiated disturbances.

1.2 Certifications

1.2.1 EU directive compliance

CE marking



The device fulfils all applicable statutory requirements of the following EU directives:

- EMC Directive 2014/30/EU, harmonized standards EN 61326-1 and EN 61326-2-3
- Devices for use in hazardous areas: ATEX Directive 2014/34/EU, harmonized standards EN 60079-0 and EN 60079-11
- CE Directive 93/68/EC
- RoHS Directive 2011/65/EU, harmonized standard EN IEC 63000.
- Radio Equipment Directive (RED) 2014/53/EU.

The manufacturer certifies successful testing of the product by applying the CE marking.

1.2.2 Ex approvals

C530X (intrinsically safe)

ATEX	KIWA 17ATEX0053 X	II 1G Ex ia IIC T6...T4 Ga
IECEX	IECEX KIWA 17.0027X	Ex ia IIC T6...T4 Ga
USA	FM18US0260X	IS CL I DIV 1 GP A-D, T6...T4 Cl I Zn 0 AEx/Ex ia IIC T6...T4 Ga
Canada	FM18CA0124X	

R530X (intrinsically safe)

ATEX	KIWA 17ATEX0055 X	II 1G Ex ia IIC T6...T4 Ga
IECEX	IECEX KIWA 17.0029X	Ex ia IIC T6...T4 Ga
USA	FM18US0260X	IS CL I DIV 1 GP A-D, T4...T6 Cl I Zn 0 AEx/Ex ia IIC T4...T6 Ga
Canada	FM18CA0124X	



Refer also to "Specific Conditions of Use" in the Ex certificates in the download area of the manufacturer's website.

1.3 Safety instructions from the manufacturer

1.3.1 Copyright and data protection

The contents of this document have been created with great care. Nevertheless, we provide no guarantee that the contents are correct, complete or up-to-date.

The contents and works in this document are subject to copyright. Contributions from third parties are identified as such. Reproduction, processing, dissemination and any type of use beyond what is permitted under copyright requires written authorisation from the respective author and/or the manufacturer.

The manufacturer tries always to observe the copyrights of others, and to draw on works created in-house or works in the public domain.

The collection of personal data (such as names, street addresses or e-mail addresses) in the manufacturer's documents is always on a voluntary basis whenever possible. Whenever feasible, it is always possible to make use of the offerings and services without providing any personal data.

We draw your attention to the fact that data transmission over the Internet (e.g. when communicating by e-mail) may involve gaps in security. It is not possible to protect such data completely against access by third parties.

We hereby expressly prohibit the use of the contact data published as part of our duty to publish an imprint for the purpose of sending us any advertising or informational materials that we have not expressly requested.

1.3.2 Disclaimer

The manufacturer will not be liable for any damage of any kind by using its product, including, but not limited to direct, indirect or incidental and consequential damages.

This disclaimer does not apply in case the manufacturer has acted on purpose or with gross negligence. In the event any applicable law does not allow such limitations on implied warranties or the exclusion of limitation of certain damages, you may, if such law applies to you, not be subject to some or all of the above disclaimer, exclusions or limitations.

Any product purchased from the manufacturer is warranted in accordance with the relevant product documentation and our Terms and Conditions of Sale.

The manufacturer reserves the right to alter the content of its documents, including this disclaimer in any way, at any time, for any reason, without prior notification, and will not be liable in any way for possible consequences of such changes.

1.3.3 Product liability and warranty

The operator shall bear responsibility for the suitability of the device for the specific purpose. The manufacturer accepts no liability for the consequences of misuse by the operator. Improper installation or operation of the devices (systems) will cause the warranty to be void. The respective "Standard Terms and Conditions" which form the basis for the sales contract shall also apply.

1.3.4 Information concerning the documentation

To prevent any injury to the user or damage to the device it is essential that you read the information in this document and observe applicable national standards, safety requirements and accident prevention regulations.

If this document is not in your native language and if you have any problems understanding the text, we advise you to contact your local office for assistance. The manufacturer can not accept responsibility for any damage or injury caused by misunderstanding of the information in this document.

This document is provided to help you establish operating conditions, which will permit safe and efficient use of this device. Special considerations and precautions are also described in the document, which appear in the form of icons as shown below.

1.3.5 Warnings and symbols used

Safety warnings are indicated by the following symbols.



DANGER!

This warning refers to the immediate danger when working with electricity.



DANGER!

This warning refers to the immediate danger of burns caused by heat or hot surfaces.



DANGER!

This warning refers to the immediate danger when using this device in a hazardous atmosphere.



DANGER!

These warnings must be observed without fail. Even partial disregard of this warning can lead to serious health problems and even death.



WARNING!

Disregarding this safety warning, even if only in part, poses the risk of serious health problems. There is also the risk of damaging the device or parts of the operator's plant.



CAUTION!

Disregarding these instructions can result in damage to the device or to parts of the operator's plant.



These instructions contain important information for the handling of the device.



LEGAL NOTICE!

This note contains information on statutory directives and standards.



• **HANDLING**

This symbol designates all instructions for actions to be carried out by the operator in the specified sequence.

➔ **RESULT**

This symbol refers to all important consequences of the previous actions.

1.4 Safety instructions for the operator



WARNING!

In general, devices from the manufacturer may only be installed, commissioned, operated and maintained by properly trained and authorized personnel.

This document is provided to help you establish operating conditions, which will permit safe and efficient use of this device.

2.1 General description

The IPAQ 530 signal conditioner is a smart, digital 2-wire universal HART[®] compatible transmitter for temperature measurements and other measurement applications in an industrial environment.

For further information about the possible measurements refer to *Intended use* on page 5.

Configuration of the transmitter is possible with:

- HART[®] 7 protocol via 4...20 mA output circuit.
- HART[®] 7 hand held terminal.
- The graphic user interface DTM.
- The third part PC software with a FSK modem for HART[®] 7 communication
- PC configuration software ConSoft with PC configuration kit ICON-X
- NFC interface in a portable device such as a smartphone.
A smartphone app, makes it possible to read, write, save and share settings directly in the field.

The PC configuration software ConSoft is used for configuration, display and documentation. The current ConSoft version is available for downloading on our website.

You can find configuration instructions in the ConSoft reference manual.

ConSoft is compatible with Windows XP/Vista/7/8/8.1/10.

C530 - In-head transmitter

The in-head transmitter is optionally available in an intrinsically safe version for installation in potentially explosive areas. These devices wear the "Ex" symbol and have an approval for mounting into classified hazardous area, zone 0, 1 and 2.

All in-head versions are intended for installation in a DIN-B head or larger according to EN 50446. As an alternative you can also mount the in-head version on a 35 mm rail according to EN 60715 with the help of the rail installation kit (for details refer to *Rail mounting kit for in-head transmitters* on page 14).

R530 - Rail-mount transmitter

The R530 rail-mount transmitter has the same features as the in-head version.

The rail-mount transmitter is optionally available in an intrinsically safe version for installation in potentially explosive areas. All devices with an Ex approval wear the "Ex" symbol. The rail-mount transmitter is intended for installation on a 35 mm rail according to EN 60715.

2.2 Nameplate



Look at the device nameplate to ensure that the device is delivered according to your order.

The transmitter can be identified by the information on the nameplates.

Nameplate for in-head transmitter

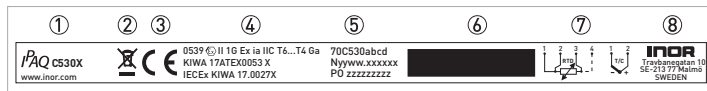

Figure 2-1: Example of nameplate for in-head transmitter

- ① Product name
- ② Electronic/electric device waste marking
- ③ CE marking (EU conformity)
- ④ Ex-relevant electrical data
- ⑤ Part number, serial number (yyww = year and week of manufacturing) and batch number
- ⑥ Printable field, sensor configuration
- ⑦ Connection diagrams
- ⑧ Manufacturer address

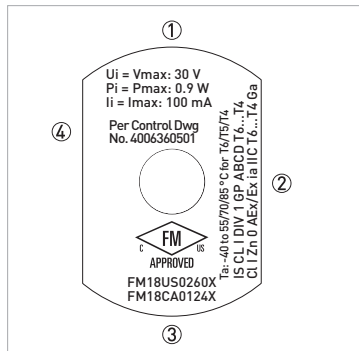

Figure 2-2: Example for bottom nameplate

- ① Electrical data for output
- ② Ex relevant electrical data and ambient temperature
- ③ Ex approvals for North America
- ④ Control drawing number

Nameplate for rail-mount transmitter

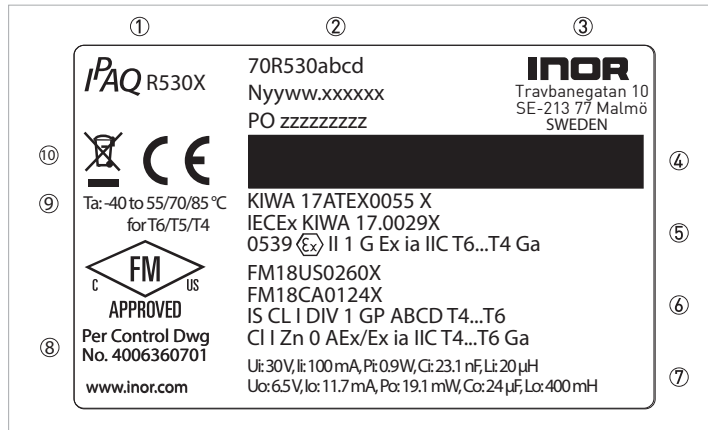

Figure 2-3: Example of nameplate for rail-mount transmitter

- ① Product name
- ② Part number, serial number (yyww = year and week of manufacturing) and batch number
- ③ Manufacturer address
- ④ Printable field, sensor configuration
- ⑤ Ex relevant electrical data and Ex approvals
- ⑥ Additional Ex relevant electrical data and Ex approvals (for example for North America)
- ⑦ Electrical data for output and input
- ⑧ Control drawing number
- ⑨ Ambient temperature
- ⑩ CE marking (EU conformity) and electronic/electric device waste marking

2.3 Versioning per NAMUR NE53

Hardware	Firmware	Firmware release date (MM/YYYY)	ConSoft	HART®	Documentation
8 ①	01.01.07 ①	04/2018	3.3.7	7.6	MA IPAQ 530 R01, R02
9 ①	01.01.10 ①	02/2019	3.4.2	7.6	MA IPAQ 530 R01, R03

① Label located on bottom side of head mounted transmitter and on the side of rail mounted transmitter.

2.4 Scope of delivery



Inspect the packaging carefully for damages or signs of rough handling. Report damage to the carrier and to the local office of the manufacturer.



Do a check of the packing list to make sure that you have all the elements given in the order.



Look at the device nameplate to ensure that the device is delivered according to your order.

The scope of delivery always consists of the transmitter and its documentation.

3.1 In-head transmitter



DANGER!

The must be installed in an enclosure having an Ingress Protection suitable for the actual use but at least IP20.

The transmitter is intended for installation in DIN B connection head or larger. For detailed information refer to *Dimensions* on page 53.

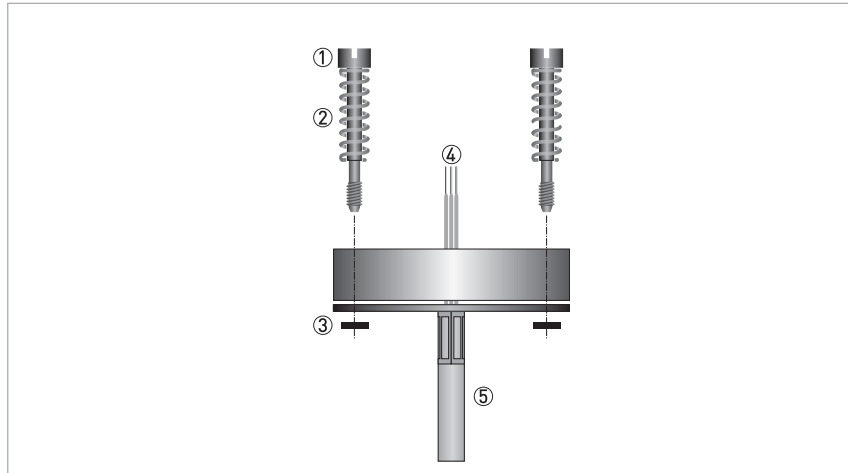

Figure 3-1: Connection head installation kit

- ① M4 screw
- ② Spring
- ③ Lock washer
- ④ Wires from the measuring insert.
- ⑤ MI cable



The connection head installation kit does not belong to the standard scope of delivery of the transmitter, you have to order it separately.



DANGER!

The transmitter is optionally available in an intrinsically safe version (zone 0, 1 and 2) for installation in potentially explosive atmospheres. The intrinsically safe version must be supplied by an intrinsically safe power supply unit or Zener barrier placed outside of the potentially explosive zone.



WARNING!

The transmitter has been developed for an operating temperature of -40...+85°C / -40...+185°F. To avoid destruction or damage of the device, always assure that the operating temperature or ambient temperature does not exceed the permissible range. The thermowell also transfer the process temperature to the transmitter housing. If the process temperature is close to or exceeds the maximum temperature of the transmitter, then the temperature in the transmitter housing can rise above the maximum permissible temperature. One way to decrease the head transfer via thermowell is to install the transmitter further away from the heat source. Inversely similar measurements can be done if the temperature gets below specified minimum temperature.



CAUTION!

For the electrical connection to the in-head transmitter, the maximum torque for screw terminals is 0.5 Nm, for both tightening and untightening the screw.

3.2 Rail mounting kit for in-head transmitters



The rail mounting kit allows to install the in-head transmitter on a rail according to EN 60715. The kit does not belong to the standard scope of delivery. You have to order it separately.

The screws in the kit is not to be used with this transmitter.

Rail mounting kit for in-head transmitters

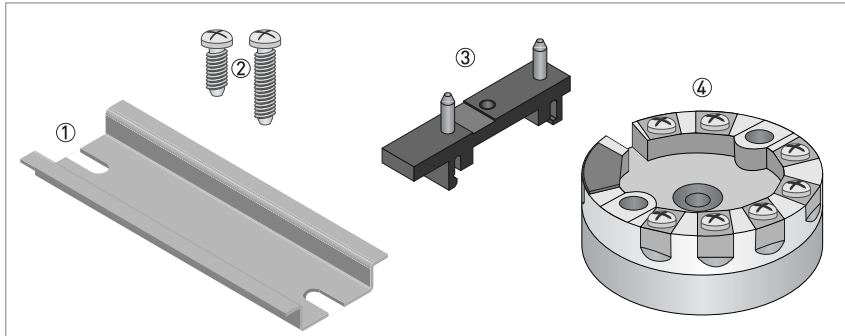
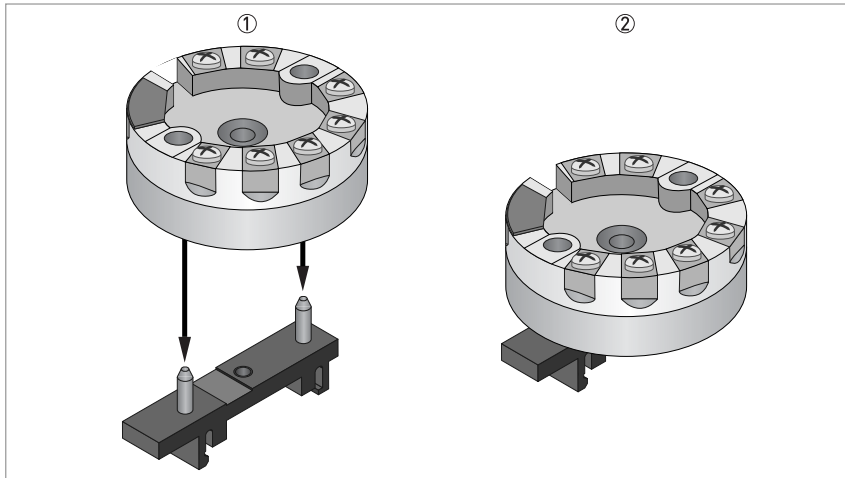

Figure 3-2: Rail mounting kit for in-head transmitters

- ① Rail (not included in the kit)
- ② Screws (not needed)
- ③ Clip
- ④ Transmitter

Installation procedure: Step 1



- ① Place the transmitter on the clip.
- ② Press down the transmitter until it is attached to the clip.

Installation procedure: Step 2

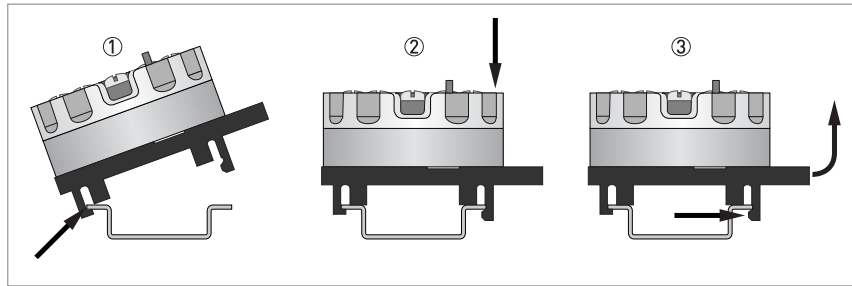

- ① Hook one end of the clip into the rail.
- ② Push the other end down until it snaps onto the rail.
- ③ Release by pushing the hook, and at the same time lift the clip out of the rail.

3.3 Rail-mount transmitter

**DANGER!**

IPAQ R530X must be installed in an enclosure having an ingress protection suitable for the actual use but at least IP20.

These transmitters are intended for installation on a 35 mm rail according to EN 60715.

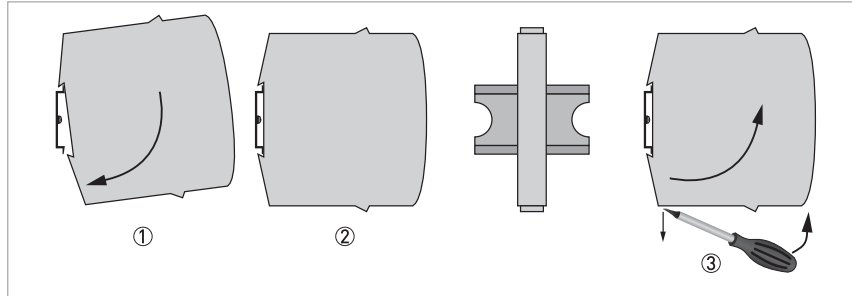

- ① Fix the upper part of the transmitter onto the rail.
- ② Press the lower part of the transmitter against the rail.
- ③ To remove the transmitter, bend the locking device using a small screwdriver. Carefully pull the transmitter in the forward direction.

**CAUTION!**

For the electrical connection to the rail-mount transmitter, the maximum torque for screw terminals is 0.25 Nm, for both tightening and untightening the screw.

**CAUTION!**

The manufacturer has developed the R530 for an operating temperature range of -40...+85°C / -40...+185°F.

To avoid destruction or damage of the device, always note the following items:

- *Assure that the operating temperature or the ambient temperature does not exceed the permissible range.*

4.1 Safety instructions



DANGER!

All work on the electrical connections may only be carried out with the power disconnected. Take note of the voltage data on the nameplate!



DANGER!

Observe the national regulations for electrical installations!



The transmitter is protected against polarity reversal. No damage will occur to the device if the polarity of the supply voltage is switched. The output will then indicate 0 mA.



DANGER!

In potentially explosive areas, the intrinsically safe versions must be used.

The C530X / R530X (intrinsically safe) can be installed in potentially hazardous area zone 0, 1 and 2 / DIV 1 and 2.

The C530X / R530X (intrinsically safe) can be installed in potentially hazardous zone 0, 1 and 2 / DIV 1 and 2 and the input may be connected to temperature sensors installed in zone 0 / DIV 1.

The intrinsically safe versions must be supplied by an intrinsically safe power supply unit or Zener barrier placed outside of the potentially explosive area.



DANGER!

Never connect or operate a non-Ex version of a transmitter in potentially explosive areas, otherwise it might cause an explosion that can result in fatal injuries! Before you connect and operate a transmitter version with an Ex approval, always note the following items to avoid an explosion which may result in fatal injuries

- *Connect the Ex version only to Ex approved sensors or sensors that meet the requirements for "simple apparatus" in EN 60079-11.*
- *Observe the corresponding regulations, the declaration of conformity, the Ex type test certificate of the device and the relevant instructions of this document.*
- *The intrinsically safe versions must be supplied by an intrinsically safe power supply unit or a Zener barrier placed outside of the potentially explosive area.*

In potentially explosive areas only Ex approved HART® modems must be used.

In order to ensure reliable HART® communication with this transmitter, the maximum cable length of the output circuit must be observed. For detailed information refer to Cable length on page 23.



WARNING!

Observe without fail the local occupational health and safety regulations.

Any work done on the electrical components of the measuring device may only be carried out by properly trained specialists.



Look at the device nameplate to ensure that the device is delivered according to your order. Check for the correct supply voltage printed on the nameplate (applies only to the intrinsically safe versions).

***DANGER!***

*For the transmitters used in hazardous areas following special conditions have to be considered:
The communication interface (USB connection) may only be connected to the associated ICON interface if the temperature transmitter is outside of the hazardous area. If certified ICON-X interface is used, a connected sensor may be located in the hazardous area. If non-Ex ICON interface is used, a connected sensor shall not be located in the hazardous area.
For the permitted ambient temperature range, refer to Temperature data for areas with potentially explosive atmospheres on page 54
The transmitter shall be mounted into a suitable enclosure that provides a degree of protection of at least IP20.
The NFC Interface for communication must not be used in hazardous areas.*

4.2 Electrical connections of in-head transmitter

The input and output signals and the power supply must be connected in accordance with the following illustrations. The transmitter is easy to install with the connection head installation kit. To avoid measuring errors, all cables must be connected properly and the screws tightened correctly.

RTD and potentiometer measurement

Pt100...Pt1000, Ni100, Ni120, Cu10 2-wire connection	Pt100...Pt1000, Ni100, Ni120, Cu10 3-wire connection	Pt100...Pt1000, Ni100, Ni120, Cu10 4-wire connection
Resistance, 2-wire connection	Resistance, 3-wire connection	Resistance, 4-wire connection
Potentiometer, 3-wire slide wire		

Thermocouple and voltage measurement

Thermocouple	Voltage	Thermocouple with external CJC (Pt100)

4.3 Connection diagram of in-head transmitter



CAUTION!

Always establish the electrical connections according to the following diagrams. Otherwise it can come to destruction or damage of the transmitter. Note that the maximum output load always depends on the power supply. If the maximum output load is exceeded, then the measured value will become incorrect. For further information refer to Technical data on page 48



To enable HART[®] communication, the output circuit must have an output load of at least 250 Ω.

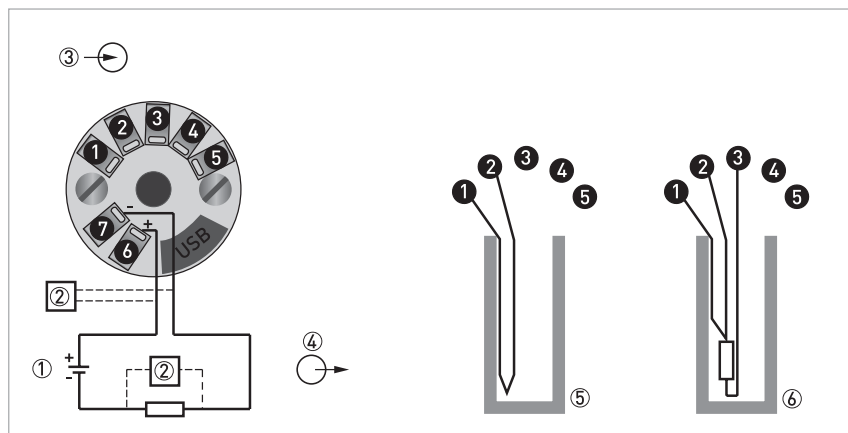

Figure 4-1: Connection diagram

- ① Voltage supply 8.5...36 VDC (terminals 6, 7)
- ② HART[®] modem
- ③ Input
- ④ Output
- ⑤ Thermocouple
- ⑥ Pt100 3-wire connection



The HART[®] modem is connected parallel to the output load or parallel to the output of the transmitter.



In order to ensure reliable HART[®] communication with this transmitter, the maximum cable length of the output circuit must be observed. For detailed information refer to Cable length on page 23.



At an ambient temperature below -30 °C the HART[®] communication might be unstable.

4.4 Connection diagram of in-head transmitter (intrinsically safe)

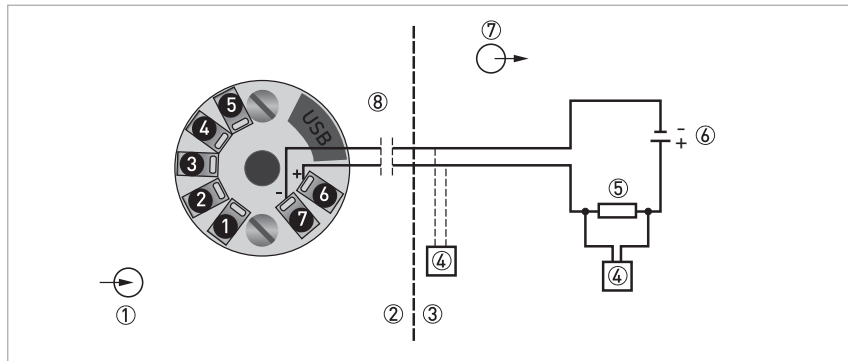

Figure 4-2: Connection diagram

- ① Input (intrinsically safe)
- ② Classified hazardous area (potentially explosive area e.g. zone 0, 1 or 2 / DIV 1, 2)
- ③ Safe area
- ④ HART[®] modem, Ex (Intrinsically safe)
- ⑤ R_{Load} (intrinsically safe), $R \geq 250 \Omega$
- ⑥ Zener barrier / Voltage supply 8.5...30 VDC and output 4...20 mA (intrinsically safe – terminals 6, 7)
- ⑦ Output
- ⑧ Refer to chapter "Cable length"



The HART[®] modem is connected in parallel to the output load or to the output of the transmitter.

**DANGER!**

The transmitter may be operated in areas with potentially explosive atmospheres if the voltage supply is ensured by means of an associated apparatus.

In potentially explosive areas only Ex approved HART[®] modems may be used. The safety instructions for operation in potentially explosive areas must be observed.

In order to ensure reliable HART[®] communication with this transmitter, the maximum cable length of the output circuit must be observed. For detailed information refer to Cable length on page 23.

4.5 Electrical connections of rail-mount transmitter

The input and output signals and the power supply must be connected in accordance with the following illustrations. To avoid measuring errors, all cables must be connected properly and the screws tightened correctly.

RTD and potentiometer measurement

Pt100...Pt1000, Ni100, Ni120, Cu10 2-wire connection	Pt100...Pt1000, Ni100, Ni120, Cu10 3-wire connection	Pt100...Pt1000, Ni100, Ni120, Cu10 4-wire connection
Resistance, 2-wire connection	Resistance, 3-wire connection	Resistance, 4-wire connection
Potentiometer, 3-wire slide wire		

Thermocouple and voltage measurement

Thermocouple	Voltage	Thermocouple with external CJC (Pt100)

4.6 Connection diagram of rail-mount transmitter

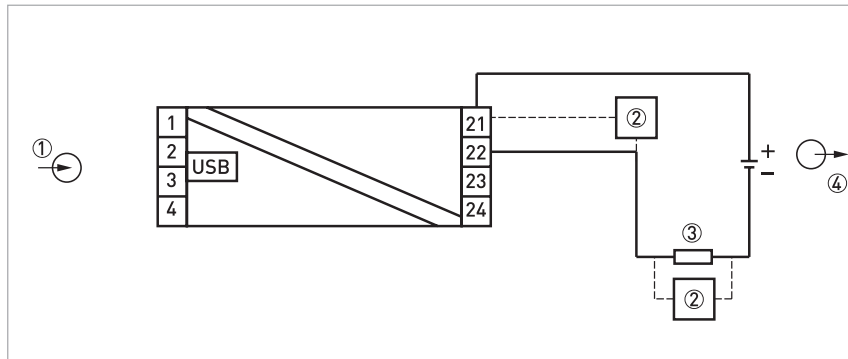

Figure 4-3: Connection diagram

- ① Input
- ② HART® modem
- ③ R_{Load} , $R \geq 250 \Omega$
- ④ Voltage supply 8.5...36 VDC and output 4...20 mA



The HART® modem is connected parallel to the output load or parallel to the output of the transmitter.

The load must be at least 250 Ω for HART® to work.

4.7 Connection diagram of rail-mount transmitter (intrinsically safe)

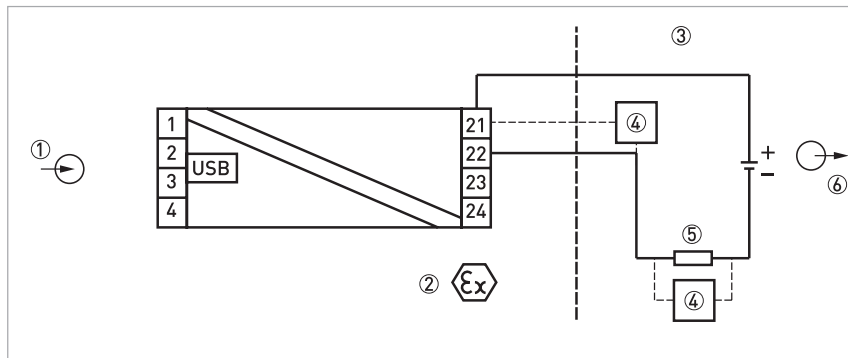

Figure 4-4: Connection diagram

- ① Input (intrinsically safe)
- ② Classified hazardous area (potentially explosive area e.g. zone 0, 1 or 2 / DIV 1, 2)
- ③ Safe area
- ④ HART® modem / Ex (intrinsically safe)
- ⑤ R_{Load} (intrinsically safe)
- ⑥ Zener barrier / Voltage supply 8.5...30 VDC and output 4...20 mA (intrinsically safe - terminals 21, 22)

**DANGER!**

The transmitter may be operated in areas with potentially explosive atmospheres if the voltage supply is ensured by means of an associated apparatus.

4.8 Cable length

In order to ensure reliable HART[®] communication, the maximum cable length of the output circuit must be observed.

To calculate the maximum cable length for the output circuit, determine the total resistance of the output loop (load resistance + approximate cable resistance). Find out the capacitance of the cable being used. In the following tables you can find the maximum cable length based on the typical values for 1 mm² cables. CN is the abbreviation for "Capacitance Number" which is multiple of 5000 pF present in the device.

Field device	Cable insulation					
	PVC		Polyethylene		Polyethylene foam	
	[m]	[ft]	[m]	[ft]	[m]	[ft]
1 (CN = 1)	600	1969	1100	3609	2000	6562
10 Multidrop (CN = 1)	500	1640	900	2953	1600	5249
10 Multidrop (CN = 4.4)	85	279	150	492	250	820

Table 4-1: Maximum length for typical 1 mm² cables

Insulation	Capacitance [pF/m]
PVC	300...400
Polyethylene	150...200
Polyethylene foam	75...100

Conductors			Resistance [Ω/km] (both conductors in series)
Area [mm ²]	Diameter [mm]	AWG	
2.0	1.6	14	17
1.3	1.3	16	28
1.0	1.15	17	36
0.8	1.0	18	45
0.5	0.8	20	70
0.3	0.6	22	110
0.2	0.5	24	160

Table 4-2: Cable parameters

For multiple connections (Multidrop mode), the following formula shall be used:

$$L = [(65 \times 10^6) / (R \times C)] \times (Cn \times 5000 + 10000) / C$$

with

L: cable length [m or ft]

R: load resistance (incl. the resistance of any Zener barrier) + cable resistance [Ω]

C: cable capacitance [pF/m or pF/ft]

Cn: number of transmitters in the loop

5.1 NFC configuration and logging

The IPAQ 530 contains an NFC interface for communication with a smartphone app. The configuration procedure uses the NFC function in combination with a smartphone with built-in NFC support to perform all settings of the transmitter. The transmitter does not need any power or other external connection, just to be close to the smartphone. The app makes it possible to read, write, save and share settings directly in the field.

The logging function give the possibility to log events directly in the field without any other equipment beside the smartphone. The logged data can be stored or shared by the mobile network. It makes it also very simple to read and display the actual measuring value in the transmitter.

The app does also give direct access to the transmitter documentation and calibration data through an internet connection.

5.2 HART[®] networks



In order to ensure reliable HART[®] communication with this transmitter, the loop resistance must be at least 250 Ω! If the USB interface (configuration modem) is connected to the transmitter then the HART[®] communication is disconnected.

5.3 Point-to-point connection analog / digital mode

Point-to-point connection between the transmitter and the HART[®] master.

The current output of the device may be active or passive.

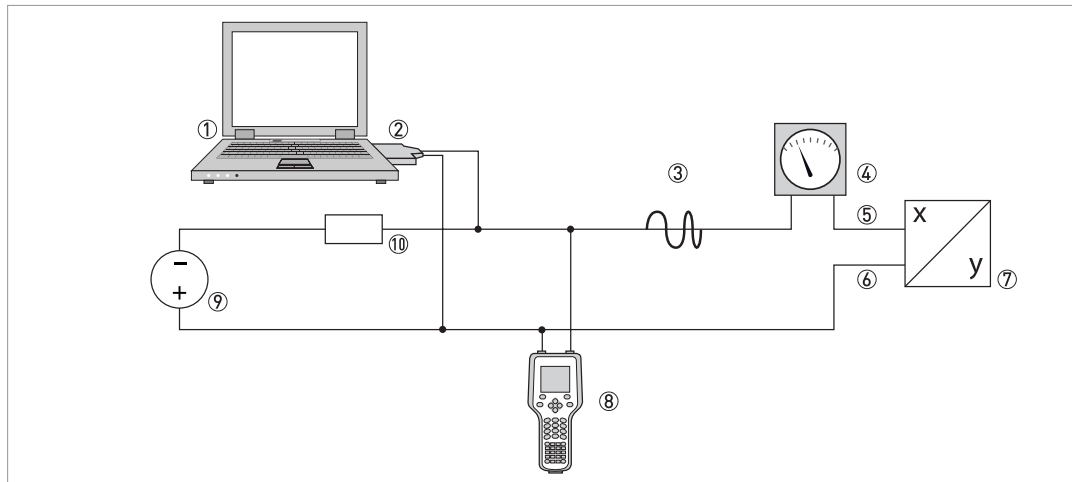

- ① Primary Master
- ② HART[®] modem
- ③ HART[®] signal
- ④ Analog indicator
- ⑤ Terminal 7
- ⑥ Terminal 6
- ⑦ Device with address = 0 and passive or active current output
- ⑧ Secondary Master
- ⑨ Power supply for devices (slaves) with passive current output
- ⑩ Load $\geq 250 \Omega$ (0hm)



At an ambient temperature below -30°C / -22°F the HART[®] communication might be unstable.

5.4 Multi-drop connection

As a multipoint connection (Multidrop) with up to 63 devices in parallel (this transmitter or other HART® devices).

The current outputs of the devices must be passive!

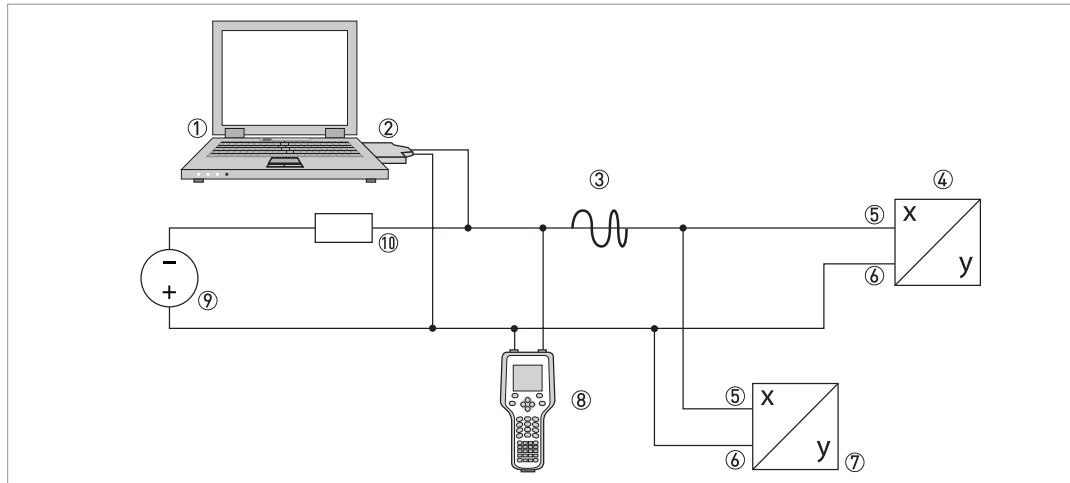

- ① Primary master
- ② HART® modem
- ③ HART® signal
- ④ Other HART® devices or this transmitter (refer also to ⑦)
- ⑤ Terminal 7
- ⑥ Terminal 6
- ⑦ Device with address > 0 and passive current output, connection of max. devices (slaves)
- ⑧ Secondary Master
- ⑨ Power supply for devices (slaves) with passive current output
- ⑩ Load $\geq 250 \Omega$ (Ohm)

5.5 Factory settings for configuration



DANGER!

Only an Ex approved HART[®] modem located in safe area may be connected to a transmitter placed in potentially explosive area.

The transmitters are delivered with either a factory settings or configured according to customers' specifications.

Menu	Parameter	Factory settings
Device Root menu		
-> Sensor	Type of sensor	RTD Pt100 $\alpha = 0.003850$
	Number of wires	3
	PV Lower range value	0
	PV Upper range value	100
	Digital units	°C
	Damping value	1.4s
	Sensor break (Downscale/Upscale)	Upscale
	Sensor short circuit (Downscale/Upscale)	Upscale

5.6 Configuration with ConSoft

The ConSoft is a PC based graphical user interface for configuration of the transmitters. The PC configuration software ConSoft is used for configuration, display and documentation. The current software versions of ConSoft and the USB interface are available for downloading on our website.



CAUTION!

When the USB interface (configuration modem) is connected to the transmitter then the HART[®] communication is disconnected, even if ConSoft is not running.

To upgrade your USB interface software to the latest version, use the following flow chart.

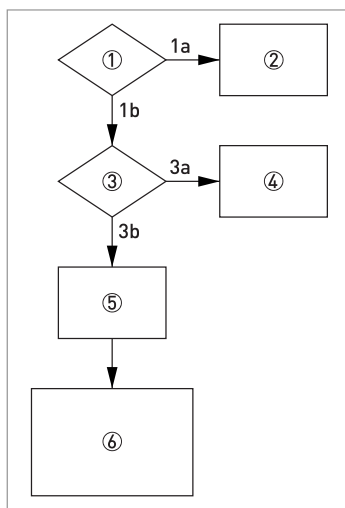

① Is the USB interface version 1.2.00 or higher?

1a No

1b Yes

② No possibility of updating for hardware version below 1.2.00. Replace the USB interface with newer version.

③ Is a ConSoft version 1.2.0.0 or higher installed on your PC?

3a No

3b Yes

④ Download the current ConSoft version from our website and install it on your PC.

⑤ Download the current software file [USB_x.y.zz.hex] for the USB interface from our website to your PC either on your desktop or in a folder made for this purpose.

⑥ 1. Start ConSoft

2. Connect the USB interface to the PC. Note that no other device should be connected during updating of the USB interface.

3. Click on Options/Update USB Interface/Load file (type the path for the software file downloaded on your desktop or in a separate folder).

4. Wait until "File OK" message is on the screen.

5. Click on "Start update". A message "Programming!" and a green status indicator show up on the screen. The update will take about one minute.

6. Wait until "Ready USB Interface" message is displayed on the screen. Close the update window. The USB interface is now ready for use.



Full functionality of the transmitter is achieved with ConSoft program version 3.2.0 or later and the firmware in the USB Interface must have a version number 1.2.07 or later. Consoft is compatible with Windows XP/Vista/7/8/8.1/10. The current software version of ConSoft and the USB interface are available for downloading on our website.



CAUTION!

Only use the manufacturer's configuration kit for PC configuration. Another configuration kit could destroy or damage the transmitter.

***DANGER!***

The transmitter's communication port (USB connection) may only be connected to the certified ICON-X Interface. When the ICON-X is connected, the temperature transmitter shall be outside of the hazardous area; a connected sensor may be located in the hazardous area.

For the applicable ambient temperature range, see the control drawings for C530X/R530X at the end of this book, and for ICON-X - 4006801801

Proper connection of the transmitters with a PC requires the USB interface which is included in the ICON-X configuration kit. For connection of the transmitters refer to the following connection diagrams during configuration.



DANGER!

Make sure the area is safe before connecting the USB interface ICON-X to the transmitter.

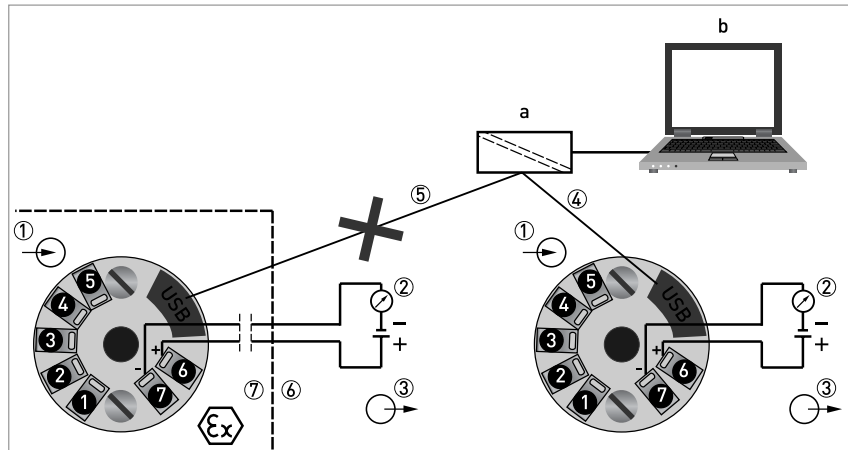

Figure 5-1: Connection during configuration of in-head transmitter

a = PC configuration kit; b = PC software ConSoft

- ① Input (intrinsically safe)
- ② R_{Load} (intrinsically safe)
- ③ Output voltage supply (intrinsically safe terminals 6 and 7)
- ④ Communication with USB interface and a PC software ConSoft
- ⑤ Connection to USB interface and a PC software ConSoft is not permitted if Ex version of IPAQ C530 (IPAQ C530X) is placed in the classified hazardous area (potentially explosive area)
- ⑥ Safe area
- ⑦ Classified hazardous area (potentially explosive area e.g. zone 0, 1 and 2 / DIV 1 and 2)

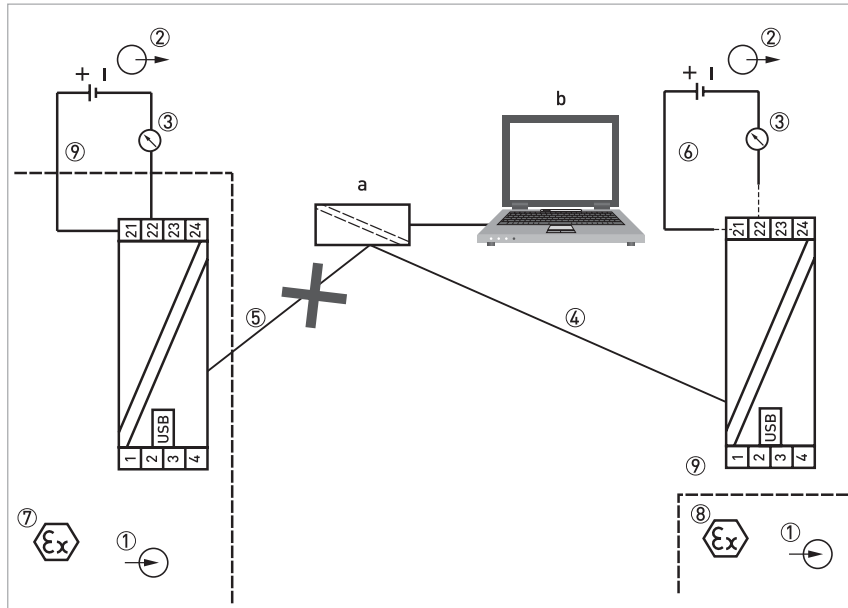

Figure 5-2: Connection during configuration of rail-mount transmitter

a = PC configuration kit; b = PC software ConSoft

- ① Input (intrinsically safe)
- ② Voltage supply (intrinsically safe terminals 21, 22)
- ③ R_{Load} (intrinsically safe)
- ④ Communication with USB interface and a PC software ConSoft
- ⑤ Connection to USB interface and a PC software ConSoft is not permitted if Ex version of IPAQ R530 (IPAQ R530X) is placed in the classified hazardous area (potentially explosive area)
- ⑥ Connection to the voltage supply during configuration with USB interface and PC software ConSoft is not needed
- ⑦ Classified hazardous area (potentially explosive area e.g. zone 0 / DIV 1)
- ⑧ Classified hazardous area (potentially explosive area e.g. zone 0, 1 and 2 / DIV 1 and 2)
- ⑨ Safe area

5.7 Configuration with a hand held communicator FC 475

The Field communicator FC 475 is a hand held communicator from Emerson Process Management for configuring HART® and Foundation Fieldbus devices. To be able to configure the transmitter with the FC 475 you need a Device Description (DD) file.

The transmitter DD has to be installed on the FC 475, otherwise the user will work with the transmitter as generic device losing opportunity to control all features of the transmitter. For installing DD on the FC 475 the "Easy Upgrade Programming Utility" is needed and the FC 475 must have a system card with "Easy Upgrade" option (see details in the "475 Field Communicator User's Manual").

The transmitter DD for FC 475 can also be downloaded from our website. For information about installing, follow the instructions in the attached "readme.txt" file.

For proper connection of transmitter with the hand held communicator refer to *Connection diagram of in-head transmitter* on page 19 and refer to *Connection diagram of rail-mount transmitter* on page 22.

To configure the transmitter for areas with potentially explosive atmospheres refer to *Connection diagram of in-head transmitter (intrinsically safe)* on page 20 and refer to *Connection diagram of rail-mount transmitter (intrinsically safe)* on page 22.

5.8 Device management software

The transmitter can be configured via the PC software as AMS (Asset Management System) and Simatic PDM.

Asset Management Solutions Device Manager (AMS)

The AMS is a PC application from Emerson Process Management for configuring and managing HART® and Foundation Fieldbus devices. For adaptation to different devices AMS uses Device Descriptions (DD).

The transmitter DD has to be installed on the AMS system and a so called "Installation Kit HART AMS" is needed (available as download on the internet). For installing the DD with the installation kit refer to the "AMS Intelligent Device Manager Books Online" section "Basic AMS Functionality /Device Configurations / Installing Device Types / Procedures /Install device types from media". Please read also the "readme.txt", which is also contained in the installation kit.

The transmitter DD for AMS can also be downloaded from our website. For information about installing, follow the instructions in the attached "readme.txt" file.

AMS supports the "EDDL Process Variables Root Menu", the "Diagnostic Root Menu" and the "Device Root Menu" for online access to the device.

Process Device Manager (PDM)

The Simatic PDM is a PC application from Siemens for configuring HART® and PROFIBUS devices. For adaptation to different devices Simatic PDM uses Device Descriptions (DD).

The transmitter DD has to be installed on the PDM System and a so called "Device Install HART PDM" is needed (available as download on the internet).

For installing the DD on PDM refer to the "PDM Manual" section 13:"Integrating Devices".Please read also the "readme.txt", which is also contained in the "Device Install".

The transmitter DD for PDM can also be downloaded from our website. For information about installing, follow the instructions in the attached "readme.txt" file.

PDM supports the "EDDL Process Variables Root Menu", the "Diagnostic Root Menu" and the "Device Root Menu" for online access to the device. Furthermore it supports the "Offline Root Menu" for offline configuration.

5.9 Configuration with PACTware

PACTware is a DTM/FDT enabled PC software, which can be downloaded from pactware.com.

To be able to configure the transmitters via PACTware, download the transmitter DTM (Device Type Manager) file from our website. For information about installing, follow the instructions in the attached "readme.txt" file.

5.10 Current output and HART[®] dynamic/device variables

The transmitters handle up to 3 measurement-related HART[®] device variables. These variables depend on the device's sensor configuration and the primary variable is represented by the output signal of 4...20 mA. See the following table for more information.

HART [®] device variable name
Process Temperature
Device Temperature
Uncorrected Process Temperature

5.11 Diagnostic information according to NAMUR NE 107

Diagnostic information about the connected sensor is available in the configuration software ConSoft or via NFC when using a portable device.

The HART® diagnostic messages are generated in accordance with NAMUR NE 107 for:

- Sensor break (failure / sensor wire break)
- Sensor short-circuit (failure / sensor wire short-circuit)
- Transmitter error (failure/transmitter error, non-correctable in the transmitter)

For complete information about all diagnostic information available from the transmitters, refer to the following tables.

Explanations according to NE 107

- C: check function
- S: not within specification
- M: maintenance required
- F: failure

The "Field Device Status" byte indicates both fault conditions and abnormal operational modes.



Whilst HART Protocol revision 6.0 and higher requires the Field Device Status to be always meaningful, in earlier protocol revisions the Field Device Status had to be set to 0 if a communication error is reported.

Messages in AMS, PDM and FC 475 device diagnostic			Actions
Standard	NE 107 Signal [12]	Error message	Error correction
Transmitter	C	Field device malfunction	Make a self test to find out more. Check even device specific diagnostic. If the error remains replace the device.
Transmitter	I	Configuration changed	Information for other softwares.
Transmitter	I	Cold start	Transmitter is in cold start mode.
Transmitter	I	Loop current fixed	Transmitter in Multi-Drop mode or loop test.
Transmitter	C	Loop current saturated	Check the limits for connected sensor. Ambient temperature is higher then stated limits for sensor, which is allocated to the primary variable analogue output. Replace the sensor allocated to the primary variable analogue output.
Transmitter	C	More status variable	Check device specific errors for more information.
Transmitter	C	Non-primary variable out of limits	Check the limits for connected sensor. Replace the sensor allocated to the non-primary variable.
Transmitter	C	Primary variable out of limits	Check the limits for connected sensor. Replace the sensor allocated to the primary variable.

Messages in AMS, PDM and FC 475 device diagnostic			Actions
Standard	NE 107 Signal [12]	Error message	Error correction
<p>Extended device status -Extended status information about the device status are supported with command 0, 9 and 48. One byte in the response of the three enumerated commands, give more detailed information, which are listed in the table below</p>			
Transmitter	M	Maintenance required	Check device specific diagnostic for more information about sensors and transmitter.
Transmitter	M	Device variable alert	Check device specific diagnostic for more information about sensors and transmitter.
Transmitter	F	Critical power failure	NA
Transmitter	N	Failure	One or more Device Variables are invalid due to a malfunction in the field device or its peripherals. Make a self test to find out more. Check even device specific diagnostic. If the error remains replace the device.
Transmitter	N	Out of specification	Indication of deviations from the permissible ambient or process conditions have been detected that may compromise measurement or control accuracy.
Transmitter	N	Function check	One or more Device Variables are temporarily invalid (e.g. frozen) due to ongoing work on the device

Messages in AMS, PDM and FC 475 device diagnostic			Actions
Device specific	Failure	Error message	Error correction
Device Specific Status (Byte 0-5) Command 48 returns in byte 0 to 13 additional device status information, which are described below.			
Transmitter	M	Underrange	Measurement is under specified range. Check the specified lower range and sensor and sensor connection. If error remains replace the sensor.
Transmitter	M	Overrange	Measurement is over specified range. Check the specified high range and sensor and sensor connection. If error remains replace the sensor.
Transmitter	F	Ad_short	See Sensor short circuit (same error cause).
Transmitter	F	Ad_open	See Sensor break (same error cause).
Transmitter	F	Sensor break	Sensor wire broken. Check the sensor and sensor connection. If error remains replace the sensor.
Transmitter	F	Sensor short circuit	Sensor wire shorted. Check the sensor and sensor. If error remains replace the sensor.
Transmitter	F	Sensor invalid	Invalid sensor selected. Check the sensor selection. If error remains replace device.
Transmitter	F	Linearization table invalid	Linearization table invalid. Check Linearization table settings. If error remains replace device.
Transmitter	F	Loop voltage too low	N/A
Transmitter	F	Dac out of range	Digital-to-Analog-Converter out of max range. Power cycle the device. If error remains replace device.
Transmitter	F	Dac feedback error (+/- 10%)	N/A
Transmitter	F	Loop resistance out of range	Loop Resistance out of range ($R_{Load} [\Omega] = (U-8.5)/0.022$). Check loop connection and voltage. If error remains replace device.
Transmitter	F	Dac acknowledge error	No acknowledge from Digital-to-Analog-Converter. Power cycle the device. If error remains replace device.
Transmitter	F	System non-recoverable errors	Internal system non-recoverable error. Power cycle the device. If error remains replace device.
Transmitter	M	Process	Maintenance required: Process
Transmitter	M	Configuration	Maintenance required: Configuration
Transmitter	M	Electronics	Maintenance required: Electronics
Transmitter	M	Sensor	Maintenance required: Sensor
Transmitter	S	Process	Out of Specification: Process
Transmitter	S	Configuration	Out of Specification: Configuration
Transmitter	S	Electronics	Out of Specification: Electronics
Transmitter	S	Sensor	Out of Specification: Sensor
Transmitter	C	Process	Check: Process
Transmitter	C	Configuration	Check: Configuration
Transmitter	C	Electronics	Check: Electronics
Transmitter	C	Sensor	Check: Sensor
Transmitter	F	Process	Failure: Process
Transmitter	F	Configuration	Failure: Configuration
Transmitter	F	Electronics	Failure: Electronics
Transmitter	F	Sensor	Failure: Sensor

Messages in AMS, PDM and FC 475 device diagnostic			Actions
Device specific	Failure	Error message	Error correction
Transmitter	M	Linearization table Underrange	N/A
Transmitter	M	Linearization table Overrange	N/A
Transmitter	S	High Alarm	Check the sensor and sensor connection. If error remains replace the sensor.
Transmitter	S	Low Alarm	Check the sensor and sensor connection. If error remains replace the sensor.

5.12 Factory default settings

The transmitters are delivered with a factory configuration Pt100 ($\alpha = 0.00385$), 3-wire connection 0...+100°C / +32...+212°F, sensor error monitoring "Upscale", filtering level 1.4 s or configured according to customer's requirements.

Due to the long-term drift of max. $\pm 0.02\%$ of span per year, a re-calibration of the transmitter is normally not needed. Should you for any reason require the re-calibration, the transmitter must be returned to the factory.

5.13 Sensor error monitoring

In case of a sensor break or short circuit the transmitter indicates this by either drop the output < 3.6 mA or lift it to > 21.0 mA. The sensor error indication is individually configurable and is set via the configuration software.

5.14 System or sensor error correction

System error correction

To perform a system error correction a dry block cell or a temperature bath together with a calibrated reference thermometer is needed. The system is the sensor + transmitter. Expose the sensor to one (one-point correction) or two (two-point correction) accurately measured temperatures (true temperatures), while the transmitter is connected to the configuration software. The true temperature(s) are entered into the software, and the transmitter automatically corrects for the system errors.

Sensor error correction

If the temperature sensor is calibrated, or the sensor error compared to the standard curve is known, then the sensor error (deviation from the standard curve) can be entered into the transmitter via the configuration software and the transmitter corrects for the sensor errors.

6.1 Accessory parts

Accessory part	Order code
Universal rail mounting kit for in-head version	70ADA00015
Connection Head installation kit	70ADA00017
Ex configuration kit including Ex approved modem (not a HART® modem), software ConSoft and cables for USB connection	70CFGUSX01
HART® PC modem USB	70MEM00003
ICON-BT Bluetooth configuration kit	70CFGBT001

6.2 Spare parts availability

The manufacturer adheres to the basic principle that functionally adequate spare parts for each device or each important accessory part will be kept available for a period of 3 years after delivery of the last production run for the device.

This regulation only applies to spare parts which are subject to wear and tear under normal operating conditions.

6.3 Availability of services

The manufacturer offers a range of services to support the customer after expiration of the warranty. These include repair, maintenance, technical support and training.



For more precise information, please contact your local sales office.

6.4 Returning the device to the manufacturer

6.4.1 General information

This device has been carefully manufactured and tested. If installed and operated in accordance with these operating instructions, it will rarely present any problems.



WARNING!

Should you nevertheless need to return a device for inspection or repair, please pay strict attention to the following points:

- *Due to statutory regulations on environmental protection and safeguarding the health and safety of the personnel, the manufacturer may only handle, test and repair returned devices that have been in contact with products without risk to personnel and environment.*
- *This means that the manufacturer can only service this device if it is accompanied by the following certificate (see next section) confirming that the device is safe to handle.*

**WARNING!**

If the device has been operated with toxic, caustic, radioactive, flammable or water-endangering products, you are kindly requested:

- *to check and ensure, if necessary by rinsing or neutralising, that all cavities are free from such dangerous substances,*
- *to enclose a certificate with the device confirming that it is safe to handle and stating the product used.*

6.4.2 Form (for copying) to accompany a returned device



CAUTION!

To avoid any risk for our service personnel, this form has to be accessible from outside of the packaging with the returned device.

Company:		Address:	
Department:		Name:	
Telephone number:		Email address:	
Manufacturer order number or serial number:			
The device has been operated with the following medium:			
This medium is:	radioactive		
	water-hazardous		
	toxic		
	caustic		
	flammable		
	We checked that all cavities in the device are free from such substances.		
	We have flushed out and neutralized all cavities in the device.		
We hereby confirm that there is no risk to persons or the environment caused by any residual media contained in this device when it is returned.			
Date:		Signature:	
Stamp:			

6.5 Disposal



LEGAL NOTICE!

Disposal must be carried out in accordance with legislation applicable in your country.

Separate collection of WEEE (Waste Electrical and Electronic Equipment) in the European Union:



According to the directive 2012/19/EU, the monitoring and control instruments marked with the WEEE symbol and reaching their end-of-life **must not be disposed of with other waste.**

The user must dispose of the WEEE to a designated collection point for the recycling of WEEE or send them back to our local organisation or authorised representative.

6.5.1 Dispose of the transmitter

Dispose of the transmitter, sensor and packaging materials in an environmentally compatible way and in accordance with the country-specific waste disposal regulations.

6.5.2 Disassembling and recycling

This section describes (in short) the instructions of handling and disassembling the device when it's reached EOL (end of life) or is disposed after usage. The information given is sufficient to gather the most important parts of the device (by the end-user) which can be used for recycling.



The products do not contain dangerous gases or materials. If there is contamination from the process, refer to Returning the device to the manufacturer on page 39.

6.5.3 Disassembling and recycling of IPAQ C530/C530X

Type	IPAQ	
Model	C530 / C530X	
Usage	Signal conditioner for resistance and voltage	
	Weight [g]	Weight [lb]
Total	35.7	0.0787
Metal parts	11.1	0.0245
Ceramic fibers	0.3	0.0007
Plastic parts	24.3	0.0536

To achieve reliability and quality performance of the product IPAQ C530/C530X is encapsulated in casting polymer plastic resulting in that dismantling of the IPAQ C530/C530X is not possible. The content of the IPAQ C530/C530X can be found in the following table.

	Material	CAS	Weight [g]	Weight [%]
	Thermoplastic PC+ABS, PA	NA	19.3	54.1
	Stainless steel	NA	5.2	14.6
	Brass	NA	3.5	9.8
	Zinc	7440-66-6	0.3	0.8
	Silicone	7440-21-3	1.0	2.8
	Epoxy	NA	3.6	10.1
	Lead free solder	NA	0.4	1.1
	Nitrile	NA	0.2	0.6
	Copper	7440-50-8	1.1	3.1
	Polyester	NA	0.2	0.6
	Nickel	7723-14-0	0.5	1.4
	Alumina (Al ₂ O ₃)	1344-28-1	0.2	0.6
	Gold (Au)	7444-57-6	0.1	0.3
	Barium titanat (BaTiO ₃)	12047-27-7	0.1	0.3

	Material	CAS	Weight [g]	Weight [%]
RoHS	Polybrominated diphenyl Ethers (PBDE)	NA	0	0
	Cadmium (Cd)	7440-43-9	0	0
	Mercury (Hg)	7439-97-6	0	0
	Lead (Pb)	7440-31-7	0	0
	Chrome VI (Cr VI)	7440-47-3	0	0
	Polybrominated biphenyls (PBB)	NA	0	0
	Bis [2-ethylhexil] phthalate (DEHP)	117-81-7	0	0
	Butyl benzyl phthalate (BBP)	85-68-7	0	0
	Dibutyl phthalate (DBP)	84-74-2	0	0
	Diisobutyl phthalate (DIBP)	84-69-5	0	0

6.5.4 Disassembling and recycling of IPAQ R530/R530X

Type	IPAQ	
Model	R530 / R530X	
Usage	Signal conditioner for resistance and voltage	
	Weight [g]	Weight [lb]
Total	69.7	0.1537
Metal parts	9.5	0.0209
Ceramic fibres	0.3	0.0007
Plastic parts	54.2	0.1195

To achieve reliability and quality performance of the product IPAQ R530/R530X is encapsulated in casting polymer plastic resulting in that dismantling of the IPAQ R530/R530X is not possible except the housing, which is sorted as plastic. The content of the IPAQ R530/R530X can be found in the following table.

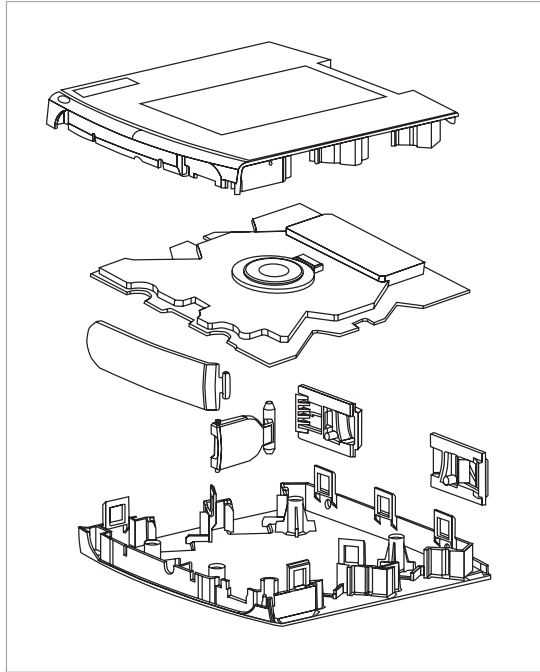

	Material	CAS	Weight [g]	Weight [%]
	Thermoplastic PC+ABS, PA	NA	49.2	70.6
	Stainless steel	NA	4.3	6.2
	Brass	NA	3.2	4.6
	Zinc	7440-66-6	0.3	0.4
	Silicone	7440-21-3	1.0	1.4
	Epoxy	NA	8.1	11.6
	Lead free solder	NA	0.6	0.9
	Copper	7440-50-8	2.2	3.2
	Polyester	NA	0.2	0.3
	Nickel	7723-14-0	0.3	0.4
	Alumina (Al ₂ O ₃)	1344-28-1	0.1	0.1
	Gold (Au)	7444-57-6	0.1	0.1
	Barium titanat (BaTiO ₃)	12047-27-7	0.1	0.1
RoHS	Polybrominated diphenyl Ethers (PBDE)	NA	0	0
	Cadmium (Cd)	7440-43-9	0	0
	Mercury (Hg)	7439-97-6	0	0
	Lead (Pb)	7440-31-7	0	0
	Chrome VI (Cr VI)	7440-47-3	0	0
	Polybrominated biphenyls (PBB)	NA	0	0
	Bis (2-ethylhexil) phthalate (DEHP)	117-81-7	0	0
	Butyl benzyl phthalate (BBP)	85-68-7	0	0
	Dibutyl phthalate (DBP)	84-74-2	0	0
	Diisobutyl phthalate (DIBP)	84-69-5	0	0

6.5.5 Packaging of IPAQ C530/C530X and R530/R530X

The products are delivered to the customers in corrugated cardboard boxes, which protect products against moisture and provides sustainable packaging solutions.

7.1 Measuring principles

The kind of the measuring principle depends on the measuring insert that you combine with the transmitter. In matters of the thermometer type the manufacturer offers two different measuring inserts, either with a resistance thermometer or with a thermocouple. This transmitter supports both types.

7.1.1 Resistance temperature sensor

The measuring insert with a temperature-sensitive sensor made from a platinum (Pt) RTD, whose value at 0°C / +32°F is 100 Ω. That is where the name "Pt100" comes from.

It is generally valid that the electric resistance of metals increases according to a mathematical function as the temperature rises. This effect is taken advantage of by resistance temperature sensors to measure temperature. The "Pt100" temperature sensors features a measuring resistance with defined characteristics, standardised in IEC 60751. The same is true for the tolerances. The average temperature coefficient of a Pt100 is $3.85 \times 10^{-3} \text{ K}^{-1}$ in the range from 0...+100°C / +32...+212°F.

During operation, a constant current I ($\leq 1 \text{ mA}$) flows through the Pt100 RTD, which brings about a voltage drop U . The resistance R is calculated using Ohm's Law ($R=U/I$). As the voltage drop U at 0°C / +32°F is 100 mV, the resulting resistance of the Pt100 temperature assembly is 100 Ω (100 mV / 1 mA = 100 Ω).

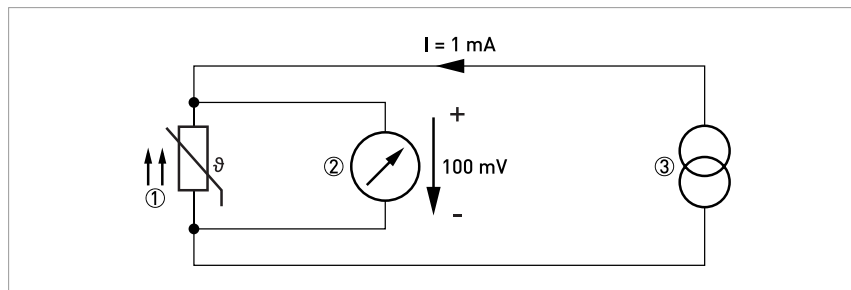

Figure 7-1: Pt100 resistance temperature sensor at 0°C / +32°F, schematic

- ① Pt100 RTD
- ② Voltage meter
- ③ Current source

7.1.2 Thermocouples

The thermocouple features two electric conductors made from different metals, connected at one end. Each free end is connected to a compensation cable which is then connected to a millivolt meter. This circuitry forms a "thermal circuit". The point at which the two electric conductors connect is called the measuring point and the point at which the compensation cables connect to the conductors of the millivolt meter is called the cold junction.

If the measuring point of this thermal circuit is heated up, a small electrical voltage (thermal voltage) can be measured. If, however, the measuring point and the cold junction are at the same temperature, no thermoelectric voltage is generated. The degree of thermoelectric voltage, also known as electromotive force (EMF), depends on the thermocouple material and the extent of the temperature difference between the measuring point and the cold junction. It can be measured using the millivolt meter with no auxiliary power.

Simply put, the thermocouple behaves like a battery, the voltage of which also increases as the temperature rises.



The characteristic curves and tolerances of commercially available thermocouples are standardised in IEC 60584.

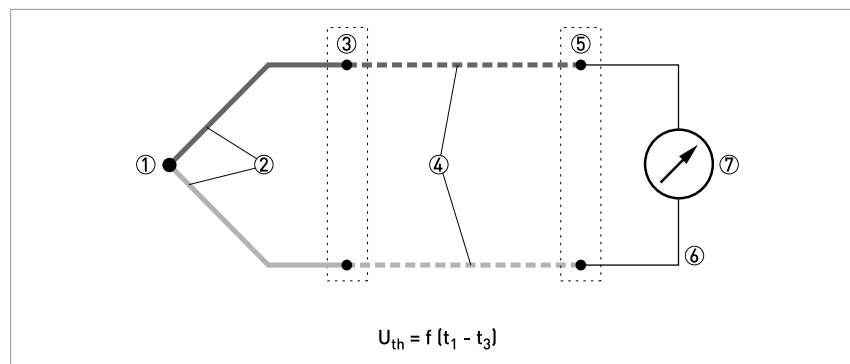

Figure 7-2: Thermocouple measuring circuit, schematic

- ① Measuring point t_1 (hot junction)
- ② Thermocouple
- ③ Transition junction t_2
- ④ Compensation cable / extension cable
- ⑤ Reference junction t_3 (cold junction)
- ⑥ Copper conductor
- ⑦ Voltage meter U_{th}

7.2 Technical data



- The following data is provided for general applications. If you require data that is more relevant to your specific application, please contact us or your local sales office.
- Additional information (certificates, special tools, software,...) and complete product documentation can be downloaded free of charge from the website.

Measuring system

Application range	Temperature measurements of solids, liquids and gases in industrial environment.
-------------------	--

Design

Versions	
C530	In-head transmitters which are intended for installation in a DIN B-head or larger according to DIN EN 50446. This transmitter is optionally available in an intrinsically safe version (zone 0, 1 and 2) for installation in potentially explosive atmospheres.
R530	Rail-mount transmitters which are intended for installation on a DIN-rail according to EN 60715, 35 mm / 1.38". The transmitter is optionally available in an intrinsically safe version (zone 0, 1 and 2) for installation in potentially explosive atmospheres.
Features	
HART® compliance	The transmitters are fully compliant with the HART® 7 protocol. HART® 7 offers the possibility to receive diagnostic information such as sensor errors or sensor conditions, transmitter error, etc.
NFC	NFC enables wireless communication and configuration between transmitter and a portable device such a smartphone.
Sensor matching	A matching to a calibrated temperature sensor can easily be performed by entering the sensor deviation in the low and high ends of the measuring ranges.
Customized linearization	For resistance and mV inputs, either a 50-point customized linearization table or via Callendar-Van Dusen (applies only to RTD, $\alpha = 0.00385$) constants can provide a correct process value.
PC programmable	Measuring ranges are set from PC.
	Full accuracy is provided without any need for calibration.
	Configuration without external power.
Runtime counter	Hour counter for elapsed operational time.
Simulated output	Fixed current output during a maximum time of 15 minutes.

Measuring accuracy

Accuracy & stability	Typical accuracy is max. of $\pm 0.08^\circ\text{C}$ or $\pm 0.08\%$ of span. (Pt100, 3- or 4-wire connection)
Ambient temperature influence	RTD and thermocouple: for detailed information refer to <i>RTD and T/C accuracy table</i> on page 57.
	Resistance: $\pm 0.01\% < 4000 \Omega$ (2000 Ω at 2-wire) $< \pm 0.02\%$ of span per $^\circ\text{C}$
	Voltage: $\pm 0.01\%$ of span per $^\circ\text{C}$
Supply voltage influence	$< \pm 0.005\%$ of span per V
Long-term drift	Max. of $\pm 0.02^\circ\text{C}$ or $\pm 0.02\%$ of span per year

Operating conditions

Temperature	
In-head transmitter	Operating and storage temperature: Standard version: -40...+85°C / -40...+185°F
	IS version: For permitted ambient temperature range, see page 55
Rail-mount transmitter	Operating and storage temperature: Standard version: -40...+85°C / -40...+185°F
	IS version: For permitted ambient temperature range, see page 55
Humidity	0...95% RH (non-condensing)
Protection category	
In-head transmitter	Housing: IP65
	Terminals: IP00
Rail-mount transmitter	Housing: IP20
	Terminals: IP20

Installation conditions

Mounting	In-head transmitter: DIN B-head or larger, DIN-rail (with adapter)
	Rail-mount transmitter: DIN-rail according to EN 60715, 35 mm / 1.38"
	For detailed information refer to <i>Installation</i> on page 13.
Weight	In-head transmitter: 35 g / 0.08 lb
	Rail-mount transmitter: 70 g / 0.15 lb
Dimensions	For detailed information refer to <i>Dimensions</i> on page 53.

Materials

Housing	PC/ABS + PA
Flammability according to UL	In-head transmitter: V0
	Rail-mount transmitter: V0/HB

Electrical connections

Power supply	Standard version: 8.5...36 VDC
	IS version: 8.5...30 VDC
Isolation	Galvanically isolated (in-out), 1500 VAC, 1 minute
Connection	Single/stranded wires: max. 1.5 mm ² / AWG 16
Terminal	Single/stranded wires: max 1.5 mm ² , max 0.5 Nm torque
Reverse Polarity Protection	Yes

Inputs / Outputs

Input - RTD	
Pt100 (IEC 60751, $\alpha = 0.00385$)	-200...+850°C / -328...+1562°F
Pt100 (JIS C1604-1981, $\alpha = 0.003916$)	
PtX (10 ≤ X ≤ 1000) (IEC 60751, $\alpha = 0.00385$)	The upper range depends on the X value, max. input temperature corresponding to 4000 Ω.
Ni100 (DIN 43760)	-60...+250°C / -76...+482°F
Ni120 (Edison No. 7)	
Ni1000 (DIN 43760)	-50...+180°C / -58...+356°F

Cu10 (Edison Copper Windings No. 15)	-50...+200°C / -58...+392°F
Sensor current	≤300 μA
Maximum sensor wire resistance	3-wire and 4-wire connection: 50 Ω/wire 2-wire connection: Compensation for 0 to 100 Ω loop resistance
Adjustment	Minimum span 10°C / 18°F Sensor error compensation ±10% of span for span <50°C / 90°F, otherwise ±5°C / ±9°F
Input - resistance / potentiometer	
Range (resistance)	0...10000 Ω
Range (potentiometer)	100...10000 Ω
Zero adjustment	Within range
Max offset adjustment	50% of selected max. value
Minimum span	10 Ω
Sensor current	≤300 μA
Customized linearization	Up to 50 points
Maximum sensor wire resistance	In-head transmitter: 50 Ω/wire Rail-mount transmitter: 50 Ω/wire
Input - thermocouples	
T/C type B - Pt30Rh-Pt6Rh (IEC 60584)	400...+1800°C / +752...+3272°F
T/C type C - W5Re-W26Re (ASTM E 988)	0...+2315°C / 32...+4199°F
T/C type D - W3Re-W25Re (ASTM E 988)	0...+2315°C / 32...+4199°F
T/C type E - NiCr-CuNi (IEC 60584)	-270...+1000°C / -454...+1832°F
T/C type J - Fe-CuNi (IEC 60584)	-210...+1200°C / -346...+2192°F
T/C type K - NiCr-NiAl (IEC 60584)	-270...+1300°C / -454...+2372°F
T/C type N - NiCrSi-NiSi (IEC 60584)	-270...+1300°C / -454...+2372°F
T/C type R - Pt13Rh-Pt (IEC 60584)	-50...+1750°C / -58...+3182°F
T/C type S - Pt10Rh-Pt (IEC 60584)	-50...+1750°C / -58...+3182°F
T/C type T - Cu-CuNi (IEC 60584)	-270...+400°C / -454...+752°F
Input impedance	>10 MΩ
Maximum wire loop resistance	In-head transmitter (including T/C sensor): 5 kΩ Field transmitter (including T/C sensor): 10 kΩ
Cold Junction Compensation (CJC)	Internal, external (Pt100) or fixed
Input - voltage	
Range	-10...+1000 mV
Zero adjustment	Within range
Minimum span	2 mV
Customized linearization	Up to 50 points
Input impedance	>10 MΩ
Maximum wire loop resistance	In-head transmitter: 5 kΩ Field transmitter / Switch room transmitter: 10 kΩ
Output	
Output signal	4...20 mA, 20...4 mA; temperature, resistance or voltage linear, customized linearization possible.

HART®	
HART® protocol	HART® 7
HART® physical layer	FSK 1200
Permissible load	(Supply voltage-8,5)/0.022
NAMUR compliance	Output limits and failure currents according to NAMUR NE 43
Adjustable filtering level	0.17...90 s, (default 1.4 s) (3-wire RTD)
Monitoring	Sensor break and short circuit monitoring, selectable, upscale ≥ 21.0 mA or downscale ≤ 3.6 mA action, individually configurable.
Configuration	
ConSoft	The PC configuration software, ConSoft, is a versatile and user-friendly tool for transmitter configuration.
	ConSoft is compatible with Windows XP/Vista/7/8/8.1/10
	ConSoft is part of the complete configuration kit, which also contains a USB interface and necessary cables. Full functionality of the transmitter is achieved with ConSoft program version 3.4.0 or later and the firmware in the USB Interface must have a version number 1.2.07 or later.
INOR connect	The app INOR Connect for portable devices (smartphones) is a versatile and user-friendly tool for wireless configuration through Bluetooth® or NFC technology. Communication via Bluetooth® requires the Bluetooth® interface - ICON-BT, which can be ordered from the manufacturer.
Alternatives	Hand held communicator, e.g. FC 475 (Emerson)
	Management systems, e.g. AMS (Emerson) and PDM (Siemens)
	EDD enabled systems
	DTM/FDT enabled systems

Approvals and certifications

CE	The device fulfils the statutory requirements of the EU directives. The manufacturer certifies that these requirements have been met by applying the CE marking.
Ex approvals	
Standard version	Without
Intrinsically safe (IS) version	Refer to Ex approvals in the separate table below.
Other standards and approvals	
Radio Equipment Directive	Directive: 2014/53/EU
	Harmonized standard: EN 300330
	Harmonized standards: EN IEC 61326-1, EN IEC 61326-2-3 EN IEC 61000-6-2, EN IEC 61000-6-4
	Harmonized standard: EN 61010-1
RoHS	Directive: 2011/65/EU Harmonized standard: EN IEC 63000
Vibration resistance	According to IEC 60068-2-6, test Fc, 10...2000 Hz, 10 g for in-head mounted / 5 g for rail mounted transmitter
Electromagnetic compatibility	NAMUR NE 21

Ex approvals

C530X (intrinsically safe)		
ATEX	KIWA 17ATEX0053 X	II 1 G Ex ia IIC T6...T4 Ga
IECEX	IECEX KIWA 17.0027X	Ex ia IIC T6...T4 Ga
USA	FM18US0260X	IS CL I DIV 1 GP A-D, T6...T4 Cl I Zn 0 AEx/Ex ia IIC T6...T4 Ga
Canada	FM18CA0124X	
R530X (intrinsically safe)		
ATEX	KIWA 17ATEX0055 X	II 1 G Ex ia IIC T6...T4 Ga
IECEX	IECEX KIWA 17.0029X	Ex ia IIC T6...T4 Ga
USA	FM18US0260X	IS CL I DIV 1 GP A-D, T6...T4 Cl I Zn 0 AEx/Ex ia IIC T6...T4 Ga
Canada	FM18CA0124X	

7.3 Dimensions

In-head transmitter

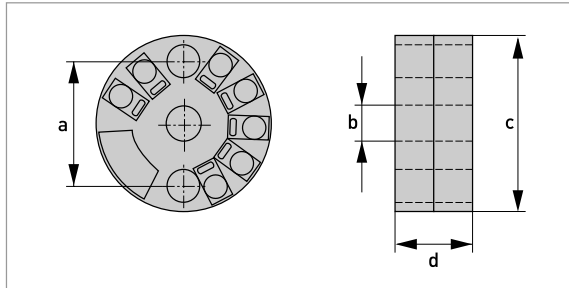

	Dimensions	
	[mm]	[inch]
a	33.0	1.30
b	7.0	0.28
c	44.5	1.75
d	19,5	0.77

Rail-mount transmitter

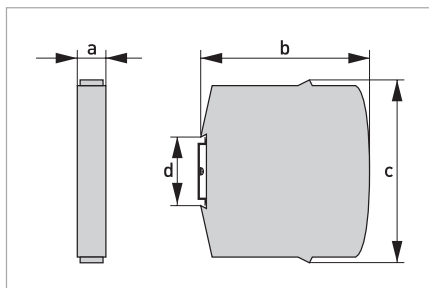

	Dimensions	
	[mm]	[inch]
a	17.5	0.69
b	81.3	3.20
c	90.0	3.54
d	35	1.38

7.4 Temperature data for areas with potentially explosive atmospheres

Intrinsically safe in head and rail mount transmitter

Pi	Temperature class	Allowed ambient temperature
900 mW	T6	$-40^{\circ}\text{C} \leq T_a \leq +55^{\circ}\text{C}$ / $-40^{\circ}\text{F} \leq T_a \leq +131^{\circ}\text{F}$
	T5	$-40^{\circ}\text{C} \leq T_a \leq +70^{\circ}\text{C}$ / $-40^{\circ}\text{F} \leq T_a \leq +158^{\circ}\text{F}$
	T4	$-40^{\circ}\text{C} \leq T_a \leq +85^{\circ}\text{C}$ / $-40^{\circ}\text{F} \leq T_a \leq +185^{\circ}\text{F}$
700 mW	T6	$-40^{\circ}\text{C} \leq T_a \leq +60^{\circ}\text{C}$ / $-40^{\circ}\text{F} \leq T_a \leq +140^{\circ}\text{F}$
	T5	$-40^{\circ}\text{C} \leq T_a \leq +75^{\circ}\text{C}$ / $-40^{\circ}\text{F} \leq T_a \leq +167^{\circ}\text{F}$
	T4	$-40^{\circ}\text{C} \leq T_a \leq +85^{\circ}\text{C}$ / $-40^{\circ}\text{F} \leq T_a \leq +185^{\circ}\text{F}$

7.5 Output load diagram

Formula for the maximum permissible output load:
 permissible $R_{Load} [\Omega] = (U-8.5)/0.022$



Shaded areas shows the working area of the HART® communication.

Standard transmitter

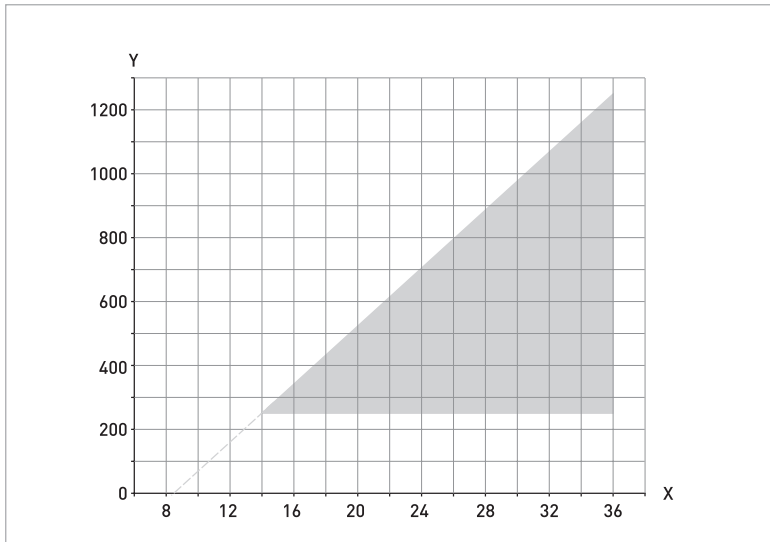

Figure 7-3: Output load diagram

X: Power supply U [VDC]
 Y: Total output load R [Ω]

Intrinsically safe transmitter

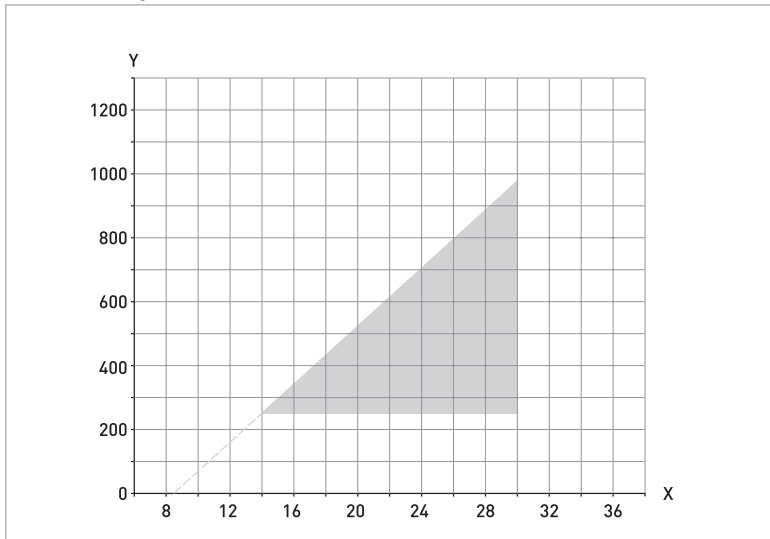

Figure 7-4: Output load diagram

X: Power supply U [VDC]
 Y: Total output load R [Ω]

7.6 Electrical data for outputs and inputs

In-head transmitter**Intrinsically safe transmitter C530X**

Output terminals 6, 7		Input terminals 1, 2, 3, 4	
$U_i = V_{\max}$	≤ 30 VDC	$U_o = U_{0C}$	≤ 6.5 VDC
$I_i = I_{\max}$	≤ 100 mA	$I_o = I_{SC}$	≤ 11.7 mA
$P_i = P_{\max}$	≤ 900 mW	P_o	≤ 19.1 mW
L_i	20 μ H	L_o	400 mH
C_i	23.1 nF	C_o	24 μ F

Rail-mount transmitter**Intrinsically safe transmitter R530X**

Output terminals 21, 22		Input terminals 1, 2, 3, 4	
$U_i = V_{\max}$	≤ 30 VDC	$U_o = U_{0C}$	≤ 6.5 VDC
$I_i = I_{\max}$	≤ 100 mA	$I_o = I_{SC}$	≤ 11.7 mA
$P_i = P_{\max}$	≤ 900 mW	P_o	≤ 19.1 mW
L_i	20 μ H	L_o	400 mH
C_i	23.1 nF	C_o	24 μ F

7.7 RTD and T/C accuracy table

Typical accuracy $\pm 0.08\%$ of span, max. of ± 0.1 K or $\pm 0.1\%$ of span. (Pt100, 3- or 4-wire connection)

Conformance level 95% (2σ)

CJC = Cold Junction Compensation

Accuracies in °C

Input type	Temp. range	Min. span	Accuracy (maximum of)	Temp. influence (Dev. from ref. temp. 20°C)
	[°C]	[°C]	[°C]	
RTD Pt100	-200...+850	10	$\pm 0.08^\circ\text{C}$ or $\pm 0.08\%$ of span ①	$\pm 0.01\%$ of span per °C
RTD PtX ②	Corresp. to max. 4 k Ω	10	$\pm 0.1^\circ\text{C}$ or $\pm 0.1\%$ of span ①	$\pm 0.01\%$ of span per °C ③
RTD Ni100	-60...+250	10	$\pm 0.1^\circ\text{C}$ or $\pm 0.1\%$ of span ①	$\pm 0.01\%$ of span per °C
RTD Ni120	-60...+250	10	$\pm 0.1^\circ\text{C}$ or $\pm 0.1\%$ of span ①	$\pm 0.01\%$ of span per °C
RTD Ni1000	-50...+180	10	$\pm 0.1^\circ\text{C}$ or $\pm 0.1\%$ of span ①	$\pm 0.01\%$ of span per °C ③
RTD Cu10	-50...+200	83	$\pm 1.5^\circ\text{C}$ or $\pm 0.2\%$ of span ①	$\pm 0.02\%$ of span per °C
T/C type B	+400...+1800	700	$\pm 1.0^\circ\text{C}$ or $\pm 0.2\%$ of span ④	$\pm 0.01\%$ of span per °C
T/C type C	0...+2315	200	$\pm 1.0^\circ\text{C}$ or $\pm 0.2\%$ of span ④	$\pm 0.01\%$ of span per °C
T/C type D	0...+2315	200	$\pm 1.0^\circ\text{C}$ or $\pm 0.2\%$ of span ④	$\pm 0.01\%$ of span per °C
T/C type E	-270...+1000	50	$\pm 0.5^\circ\text{C}$ or $\pm 0.1\%$ of span ④	$\pm 0.01\%$ of span per °C
T/C type J	-210...+1200	50	$\pm 0.5^\circ\text{C}$ or $\pm 0.1\%$ of span ④	$\pm 0.01\%$ of span per °C
T/C type K	-270...+1300	50	$\pm 0.5^\circ\text{C}$ or $\pm 0.1\%$ of span ④	$\pm 0.01\%$ of span per °C
T/C type N	-100...+1300	100	$\pm 0.5^\circ\text{C}$ or $\pm 0.1\%$ of span ④	$\pm 0.01\%$ of span per °C
T/C type N	-270...-100	100	$\pm 1.0^\circ\text{C}$ ④	$\pm 0.1\%$ of span per °C
T/C type R	-50...+1750	300	$\pm 1.0^\circ\text{C}$ or $\pm 0.1\%$ of span ④	$\pm 0.01\%$ of span per °C
T/C type S	-50...+1750	300	$\pm 1.0^\circ\text{C}$ or $\pm 0.1\%$ of span ④	$\pm 0.01\%$ of span per °C
T/C type T	-270...+400	50	$\pm 0.25^\circ\text{C}$ or $\pm 0.2\%$ of span ④	$\pm 0.01\%$ of span per °C

① Valid for 3- and 4-wire connection. For factory settings Pt100, 3-wire connection, 0..100°C applies $\pm 0.05^\circ\text{C}$.

② ($10 \leq X \leq 1000$)

③ For 2-wire connection and span $> 2000 \Omega$ applies $\pm 0.02\%$ of span per °C

④ CJC error not included. $\leq 0.5^\circ\text{C}$ within ambient temperature range

Accuracies in °F

Input type	Temp. range	Min. span	Accuracy (maximum of)	Temp. influence (Dev. from ref. temp. 68°F)
	[°F]	[°F]	[°F]	
RTD Pt100	-328...+1562	18	±0.14°F or ±0.08% of span ①	±0.006% of span per °F
RTD PtX ②	Corresp. to max. 4 kΩ	18	±0.18°F or ±0.1% of span ①	±0.006% of span per °F ③
RTD Ni100	-76...+482	18	±0.18°F or ±0.1% of span ①	±0.006% of span per °F
RTD Ni120	-76...+482	18	±0.18°F or ±0.1% of span ①	±0.006% of span per °F
RTD Ni1000	-58...+356	18	±0.18°F or ±0.1% of span ①	±0.006% of span per °F ③
RTD Cu10	-58...+392	149	±2.7°F or ±0.2% of span ①	±0.006% of span per °F
T/C type B	+752...+3272	1260	±1.8°F or ±0.1% of span ④	±0.006% of span per °F
T/C type C	+32...+4199	360	±1.8°F or ±0.1% of span ④	±0.006% of span per °F
T/C type D	+32...+4199	360	±1.8°F or ±0.1% of span ④	±0.006% of span per °F
T/C type E	-454...+1832	90	±0.9°F or ±0.1% of span ④	±0.006% of span per °F
T/C type J	-346...+2192	90	±0.9°F or ±0.1% of span ④	±0.006% of span per °F
T/C type K	-454...+2372	90	±0.9°F or ±0.1% of span ④	±0.006% of span per °F
T/C type N	-148...+2372	180	±0.9°F or ±0.1% of span ④	±0.006% of span per °F
T/C type N	-454...-148	180	±1.8°F ④	±0.18% of span per °F
T/C type R	-58...+3182	540	±1.8°F or ±0.1% of span ④	±0.006% of span per °F
T/C type S	-58...+3182	540	±1.8°F or ±0.1% of span ④	±0.006% of span per °F
T/C type T	-454...+752	90	±0.9°F or ±0.1% of span ④	±0.006% of span per °F

① Valid for 3-wire, 4-wire connection. For factory settings Pt100, 3-wire, 32-212 °F applies ±0.09 ° F.

② (10 ≤ X ≤ 1000)

③ For 2-wire connection and span >2000 Ω applies ±0.02% of span per 1.8° F

④ CJC error not included. ≤ 0.9°F within ambient temperature range

This drawing is property of Inor Process AB, Malmö, Sweden, without whose permission it may not be copied, and the contents thereof must not be imparted to third party nor be used for any unauthorized purpose. Contravention will be prosecuted.

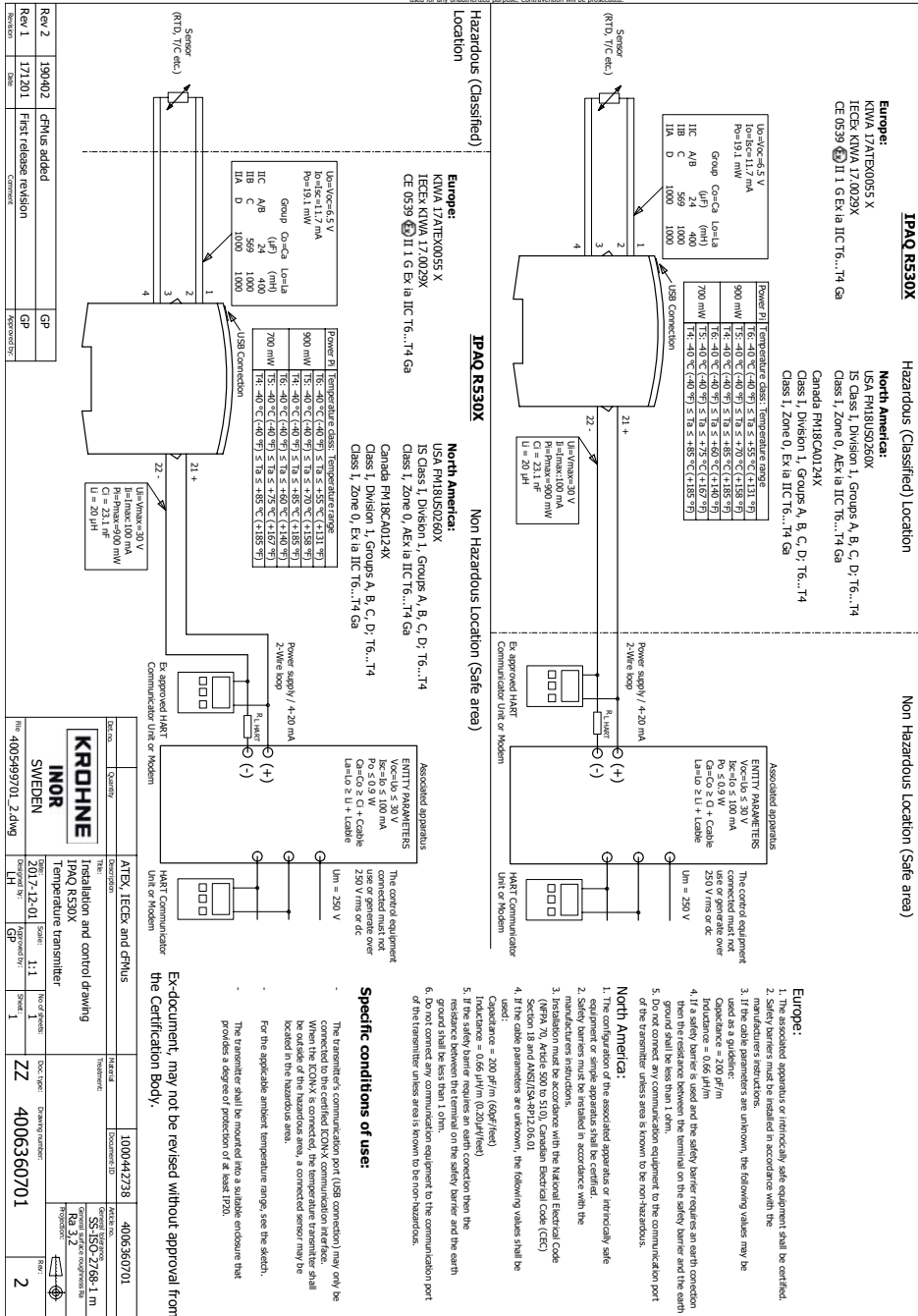

REVISION	DATE	DESCRIPTION	BY	CHKD
Rev 2	19Q402	CFHus added	GP	GP
Rev 1	171201	First release revision	GP	GP

<p>KROHNE INOR SWEDEN</p> <p>ENTTY PARAMETERS Voc=Lo ≤ 30 V Ioc=Io ≤ 100 mA Po ≤ 0.9 W Ch-Co ≥ 0 + Cable L=144 ≥ 1L + Load Um = 250 V</p>	<p>ATEX, IECEX and CFHus Insulation and control drawing IPAQ R530X Temperature transmitter</p>	<p>1000-H42738 4006360701</p>	<p>2017-12-01 1:1 1</p>	<p>2017-12-01 1:1 1</p>	<p>4006360701 2</p>
--	---	--	---	---	----------------------------------

Product liability and guarantee

Use of IPAQ 530 series transmitters for other than the intended purpose or improper installation and operation may lead to loss of the guarantee. The guarantee shall likewise be void if the device is damaged or its function otherwise impaired.

INOR Process AB, or any other affiliated company within the INOR Group (hereinafter jointly referred to as "INOR"), hereby warrants that the Product will be free from defects in materials or workmanship for a period of five (5) years from the date of delivery ("Limited Warranty"). This Limited Warranty is limited to repair or replacement at INOR's option and is effective only for the first end-user of the Product. Upon receipt of a warranty claim, INOR shall respond within a reasonable time period as to its decision concerning:

- 1 Whether INOR acknowledges its responsibility for any asserted defect in materials or workmanship; and, if so,
- 2 the appropriate cause of action to be taken (i.e. whether a defective product should be replaced or repaired by INOR).

This Limited Warranty applies only if the Product:

- 1 is installed according to the instructions furnished by INOR;
- 2 is connected to a proper power supply;
- 3 is not misused or abused; and
- 4 there is no evidence of tampering, mishandling, neglect, accidental damage, modification or repair without the approval of INOR or damage done to the Product by anyone other than INOR.

This Limited Warranty is provided by INOR and contains the only express warranty provided.

INOR SPECIFICALLY DISCLAIMS ANY EXPRESS WARRANTY NOT PROVIDED HEREIN AND ANY IMPLIED WARRANTY, GUARANTEE OR REPRESENTATION AS TO SUITABILITY FOR ANY PARTICULAR PURPOSE, PERFORMANCE, QUALITY AND ABSENCE OF ANY HIDDEN DEFECTS, AND ANY REMEDY FOR BREACH OF CONTRACT, WHICH BUT FOR THIS PROVISION, MIGHT ARISE BY IMPLICATION, OPERATION OF LAW, CUSTOM OF TRADE OR COURSE OF DEALING, INCLUDING IMPLIED WARRANTIES OF MERCHANTABILITY AND FITNESS FOR A PARTICULAR PURPOSE. EXCEPT AS PROVIDED HEREIN, INOR FURTHER DISCLAIMS ANY RESPONSIBILITY FOR LOSSES, EXPENSES, INCONVENIENCES, SPECIAL, DIRECT, SECONDARY OR CONSEQUENTIAL DAMAGES ARISING FROM OWNERSHIP OR USE OF THE PRODUCT.

Products that are covered by the Limited Warranty will either be repaired or replaced at the option of INOR. Customer pays freight to INOR, and INOR will pay the return freight by post or other "normal" way of transport. If any other type of return freight is requested, customer pays the whole return cost.