



INSTRUMENTS

65-2335RK
Carbon Monoxide Transmitter
Operator's Manual

Part Number: 71-0177RK

Revision: A

Released: 1/20/20

WARNING

Read and understand this instruction manual before operating transmitter. Improper use of the transmitter could result in bodily harm or death.

Periodic calibration and maintenance of the transmitter is essential for proper operation and correct readings. Please calibrate and maintain this transmitter regularly! Frequency of calibration depends upon the type of use you have and the sensor types. Typical calibration frequencies for most applications are between 3 and 6 months, but can be required more often or less often based on your usage.

Product Warranty

RKI Instruments, Inc. warrants gas alarm equipment sold by us to be free from defects in materials, workmanship, and performance for a period of one year from date of shipment from RKI Instruments, Inc. Any parts found defective within that period will be repaired or replaced, at our option, free of charge. This warranty does not apply to those items which by their nature are subject to deterioration or consumption in normal service, and which must be cleaned, repaired, or replaced on a routine basis. Examples of such items are:

- a) Absorbent cartridges
- b) Pump diaphragms and valves
- c) Fuses
- d) Batteries
- e) Filter elements

Warranty is voided by abuse including mechanical damage, alteration, rough handling, or repair procedures not in accordance with the operator's manual. This warranty indicates the full extent of our liability, and we are not responsible for removal or replacement costs, local repair costs, transportation costs, or contingent expenses incurred without our prior approval.

THIS WARRANTY IS EXPRESSLY IN LIEU OF ANY AND ALL OTHER WARRANTIES AND REPRESENTATIONS, EXPRESSED OR IMPLIED, AND ALL OTHER OBLIGATIONS OR LIABILITIES ON THE PART OF RKI INSTRUMENTS, INC. INCLUDING BUT NOT LIMITED TO, THE WARRANTY OF MERCHANTABILITY OR FITNESS FOR A PARTICULAR PURPOSE. IN NO EVENT SHALL RKI INSTRUMENTS, INC. BE LIABLE FOR INDIRECT, INCIDENTAL, OR CONSEQUENTIAL LOSS OR DAMAGE OF ANY KIND CONNECTED WITH THE USE OF ITS PRODUCTS OR FAILURE OF ITS PRODUCTS TO FUNCTION OR OPERATE PROPERLY.

This warranty covers instruments and parts sold to users by authorized distributors, dealers, and representatives as appointed by RKI Instruments, Inc.

We do not assume indemnification for any accident or damage caused by the operation of this gas monitor, and our warranty is limited to the replacement of parts or our complete goods.

Table of Contents

Overview	5
Specifications	5
Description	6
CO Detector	7
Amplifier	8
Junction Box	9
Installation	9
Mounting the CO Transmitter	9
Wiring the CO Transmitter to a Controller	10
Startup	11
Introducing Incoming Power	11
Setting the Zero Signal	12
Maintenance	13
Preventive Maintenance	13
Troubleshooting	13
Replacing Components of the CO Transmitter	14
Calibration Frequency	17
Calibration	17
Preparing for Calibration	17
Setting the Zero Reading	18
Setting the Response Reading	18
Returning to Normal Operation	18
Parts List	19

Overview

This instruction manual describes the 65-2335RK carbon monoxide (CO) transmitter. This manual also describes how to install, start up, configure, maintain, and calibrate the transmitter when using it with a gas monitoring controller. A parts list at the end of this manual lists replacement parts and accessories for the CO transmitter. See the controller operator's manual for information specific to the controller.

Specifications

Table 1 lists specifications for the CO transmitter.

Table 1: Specifications

Target Gas	Carbon Monoxide
Sampling Method	Diffusion
Detection Range	0 to 300 ppm
Accuracy	$\pm 5\%$ of reading or ± 5 ppm CO (whichever is greater)
Signal Output	4 to 20 mA
Response Time	90% in 30 seconds

WARNING: *When using the 65-2335RK, you must follow the instructions and warnings in this manual to assure proper and safe operation of the 65-2335RK and to minimize the risk of personal injury. Be sure to maintain and periodically calibrate the 65-2335RK as described in this manual.*

Description

This section describes the components of the CO transmitter. The CO transmitter is a 4 - 20 mA type detector head. It consists of the CO detector, amplifier, and junction box.

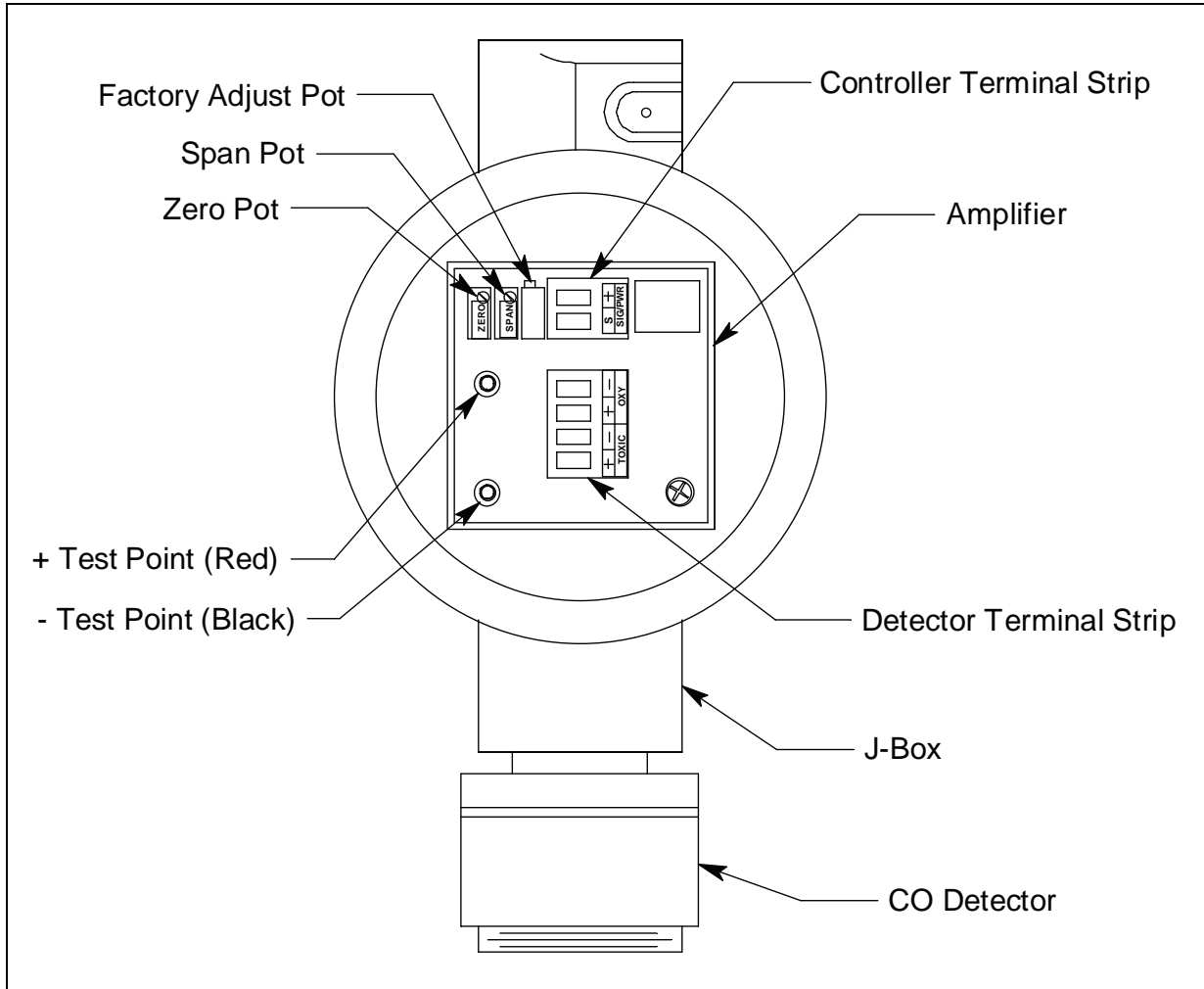

Figure 1: CO Transmitter Component Location

CO Detector

The CO detector includes the detector housing body, detector housing, cap, cap gasket, plug-in sensor, and charcoal filter.

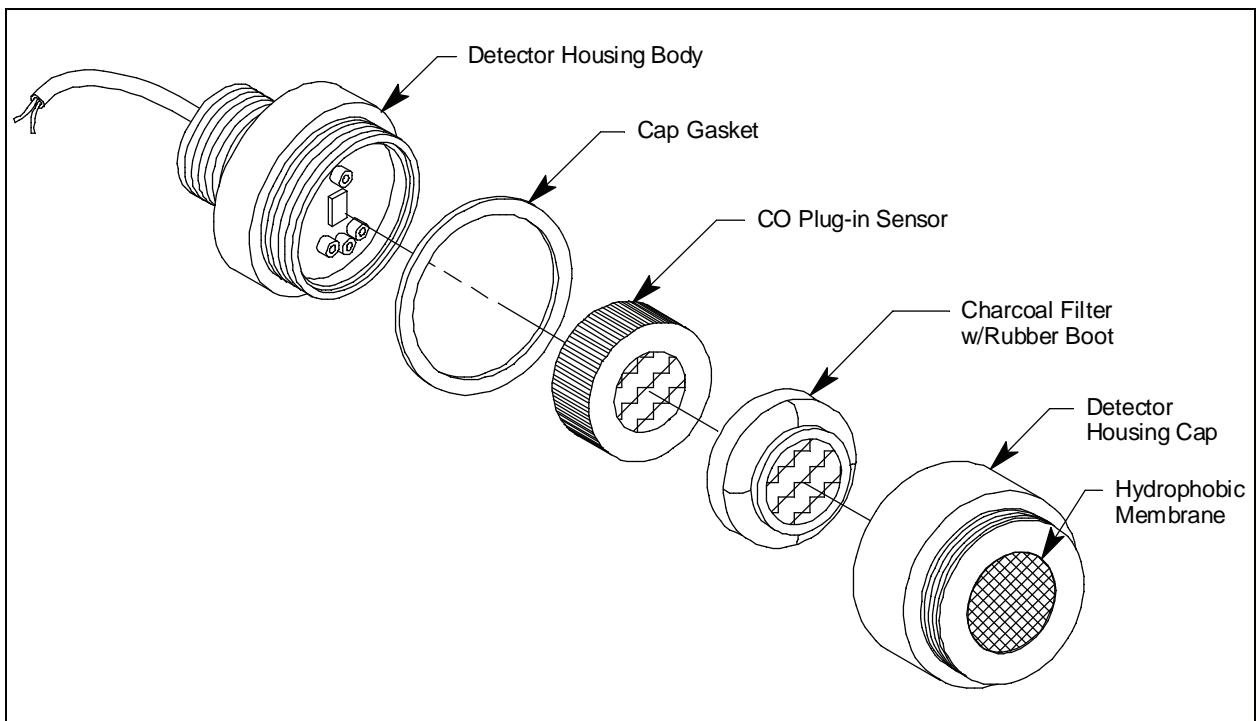

Figure 2: CO Detector Component Location

Detector Housing Body

The detector housing body protects the electronic components within the housing. Use the mounting threads at the top of the detector housing to screw the CO detector into a 3/4 NPT hub on the bottom of the junction box. Two wires extend from the top of the detector housing body. Use these wires to connect the CO detector to the amplifier. One of the wires is black and one of the wires is red.

The housing body includes a four-socket pattern at the bottom of the housing body. This socket pattern accepts the sensor's four pins to secure the sensor within the detector housing. A pre-amplifier, located between the sockets and the two interconnect wires, conditions the sensor's signal before the signal reaches the controller.

Housing Cap & Cap Gasket

The housing cap screws onto the detector housing. It retains the sensor and the rubber boot with the charcoal filter and protects them from damage. A hydrophobic membrane on the outside of the cap face keeps water and particulates away from the charcoal filter and sensor face behind the cap. Unscrew the detector cap to access the charcoal filter and sensor for maintenance or replacement. A cap gasket seals the interface between the housing and cap.

Plug-In CO Sensor

The plug-in sensor is secured in the detector assembly by the housing cap. Through a series of chemical and electrical reactions, the sensor produces an electrical output that corresponds to the detection range of the detector.

Charcoal Filter

The disc-shaped charcoal filter is secured to the face of the CO sensor with a rubber boot. The charcoal filter prevents interference gases (hydrogen sulfide [H₂S] and certain hydrocarbons) from producing false CO readings.

Amplifier

The amplifier converts the electrical output from the detector to a 4 to 20 mA signal that corresponds to the detection range and transmits the signal to a gas monitoring controller. A foam gasket that orients the amplifier and keeps it from rotating is installed on the bottom of the amplifier. The amplifier includes the controller terminal strip, detector terminal strip, zero pot, span pot, and test points (see Figure 1).

Controller Terminal Strip

The controller terminal strip is a two position plug-in style terminal strip located at the top edge of the amplifier. Use the controller terminal strip to wire the amplifier to a controller.

Detector Terminal Strip

The detector terminal strip is a four position plug-in style terminal strip located below the controller terminal strip. Two of the positions are for use with an oxygen detector and are not used in the CO transmitter. Use the two detector terminal strip positions that are labeled “TOXIC” to connect the detector to the amplifier.

NOTE: The detector is factory-wired to the detector terminal strip. See “Wiring the CO Transmitter to a Controller” on page 10 for all wiring procedures related to the transmitter.

Zero Pot

The zero pot is located in the upper left corner of the amplifier (see Figure 1). Use a small flat blade screwdriver to turn the zero pot’s adjustment screw and adjust the amplifier’s zero (CO free) output during the start-up and calibration procedure. Turn the adjustment screw clockwise to increase the zero output and counterclockwise to decrease the zero output.

Span Pot

The span pot is located to the right of the zero pot (see Figure 1). Use a small flat blade screwdriver to turn the span pot’s adjustment screw and adjust the amplifier’s response output during the start-up and calibration procedure. Turn the adjustment screw clockwise to increase the response output and counterclockwise to decrease the response output.

CAUTION: *The amplifier includes an additional pot. It is factory-set. Do not adjust it.*

Test points

The test points are on the left side of the amplifier (see Figure 1). The test points produce a 100 mV to 500 mV output that corresponds to the transmitter’s 4 to 20 mA output. Use the test points and a voltmeter to measure the amplifier’s output during the start-up and calibration procedures. The black test point in the lower left corner is the negative (-) test point and the red test point below the zero pot is the positive (+) test point.

Junction Box

Use the junction box to install the transmitter at a mounting site that is remote from the controller. The junction box protects the amplifier and wiring connections made to the amplifier. Use the top 3/4 NPT conduit hub to connect wiring from the amplifier to the controller. Use the cover on the front of the junction box to access the interior of the junction box. The detector and amplifier are factory installed in the junction box. Three spacers installed on the back of the junction box control the distance of the junction box from a mounting surface and ensure that there is enough room to install a calibration cup on the detector during calibration.

Installation

This section describes procedures to mount the CO transmitter in the monitoring environment and wire the transmitter to a controller.

Mounting the CO Transmitter

1. Select a mounting site that is representative of the monitoring environment. Consider the following when you select the mounting site.
 - Select a site where the transmitter is not likely to be bumped or disturbed. Make sure there is sufficient room to perform start-up, maintenance, and calibration procedures.
 - Select a site that is at normal breathing level.

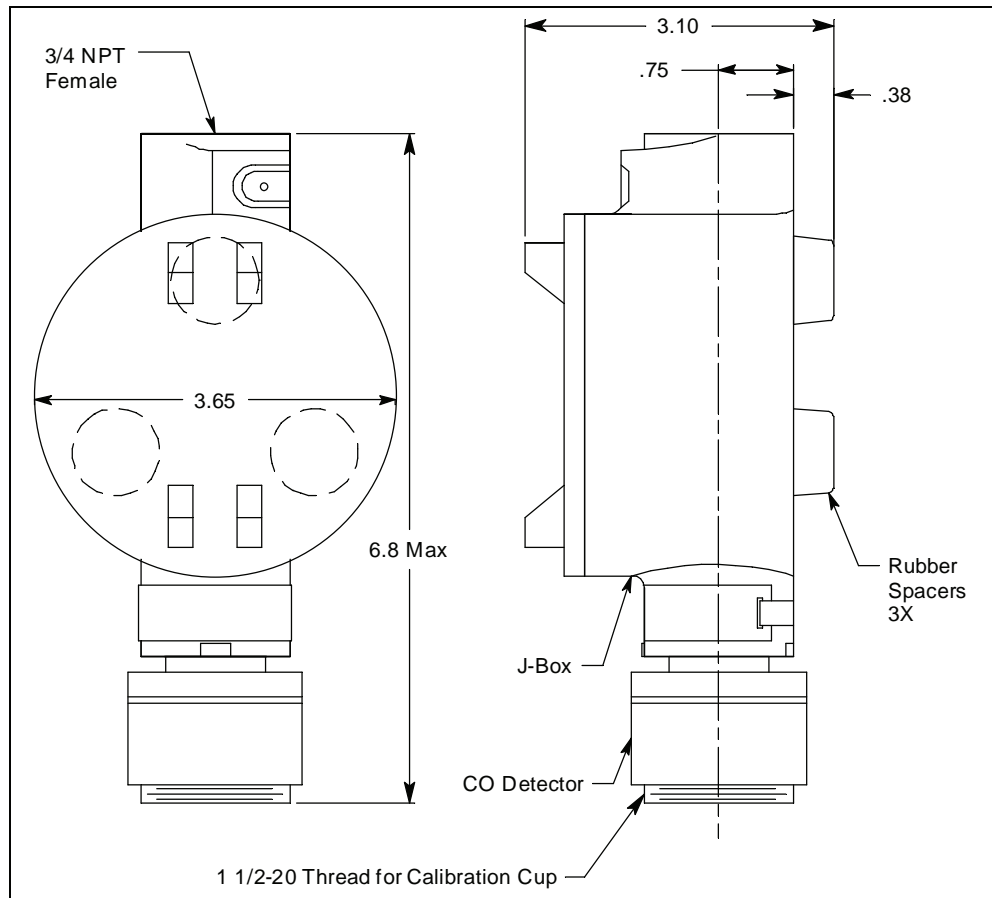

Figure 3: Mounting the CO Transmitter

2. At the monitoring site you select, hang or mount the junction box with the detector facing down (see Figure 3).

Wiring the CO Transmitter to a Controller

WARNING: *Always verify that power to the controller is off before you make wiring connections.*

1. Turn off the controller.
2. Turn off power to the controller.
3. Remove the junction box cover.
4. The detector leads are factory wired. Verify that the detector leads are wired to the amplifier's detector terminal strip as shown in Figure 4.
5. To gain access to a plug-in terminal strip for wiring, pull it out of its socket by grasping the terminal strip and pulling. The detector terminal strip is keyed so that the controller and detector terminal strips cannot be reversed inadvertently.
6. Guide either a two-conductor, shielded cable, or two wires in conduit through the top conduit hub of the junction box.
7. Pull out the controller terminal strip, and connect the two wires to the terminal strip as follows (see Figure 4).
 - Connect the positive wire to the **SIG/PWR “+”** terminal.
 - Connect the signal wire to the **SIG/PWR “S”** terminal.

CAUTION: *If shielded cable is used, leave the cable shield's drain wire disconnected and insulated at the transmitter. You will connect the opposite end of the cable's drain wire to the controller's chassis (earth) ground.*

8. Reinstall the controller terminal strip into its socket.
9. Secure the junction box cover to the junction box.
10. Route the cable or wires leading from the CO transmitter through one of the conduit hubs at the controller housing.

CAUTION: *Do not route power and transmitter wiring through the same controller conduit hub. The power cable may disrupt the transmission of the transmitter signal to the controller.*

11. Connect the wires to the applicable detector/transmitter terminal strip at the controller as shown in Figure 4.

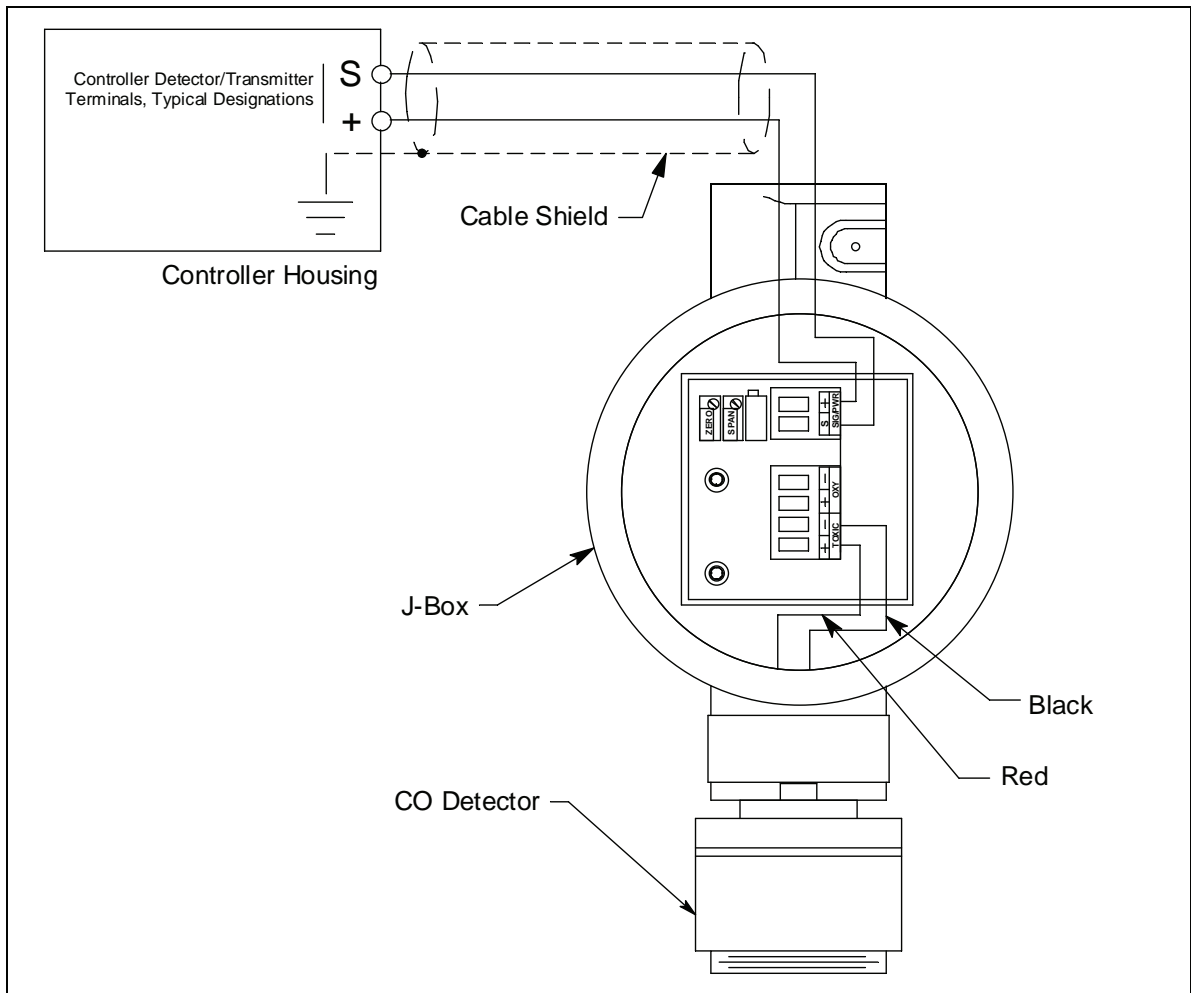

Figure 4: Wiring the CO Transmitter to a Controller

12. If shielded cable is used, connect the cable's drain wire to an available chassis (earth) ground at the controller. RKI controllers typically have a ground stud that can be used to ground the cable's drain wire.

Start Up

This section describes procedures to start up the CO transmitter and place the transmitter into normal operation.

Introducing Incoming Power

1. Complete the installation procedures described earlier in this manual.
2. Verify that the power wiring to the controller is correct and secure. Refer to the controller operator's manual.
3. Turn on power to the controller.
4. Turn on the controller.
5. Verify that the controller is on and operating properly. Refer to the controller operator's manual.

CAUTION: Allow the transmitter to warm up for 5 minutes before you continue with the next section, “Setting the Zero Signal”.

Setting the Zero Signal

CAUTION: If you suspect the presence of the target gas in the monitoring environment, use the calibration kit and the zero air calibration cylinder to introduce “fresh air” to the sensor and verify an accurate zero setting.

NOTE: If you can verify that the detector is in a fresh air environment (environment known to be of normal oxygen content and free of toxic and combustible gases), it is not necessary to apply zero air when verifying or setting the fresh air reading.

The procedure below describes applying zero emission air, usually called zero air, using a calibration kit that includes a calibration cup, calibration gas, sample tubing, and a fixed flow regulator with an on/off knob. RKI Instruments, Inc. recommends using a 0.5 LPM (liters per minute) fixed flow regulator.

1. Unscrew and remove the junction box cover from the junction box.
2. Set a voltmeter to measure in the millivolt (mV) range.
3. Plug the voltmeter leads into the test points on the amplifier. Plug the positive lead into the red (+) test point; plug the negative lead into the black (-) test point.
4. Screw the calibration cup onto the bottom of the CO detector.
5. Screw the regulator into the zero air calibration cylinder.
6. Use the sample tubing to connect the regulator to the calibration cup.
7. Turn the regulator’s on/off knob counterclockwise to open it. Gas will begin to flow.
8. Allow the gas to flow for two minutes.
9. Verify a voltmeter reading of 100 mV (± 2 mV).
10. If necessary, use a small flat-blade screwdriver to adjust the zero pot until the voltmeter reading is 100 mV (± 2 mV).
11. Turn the regulator’s on/off knob clockwise to close it.
12. Unscrew the calibration cup from the detector.
13. Unscrew the regulator from the zero air calibration cylinder. For convenience, leave the sample tubing connected to the regulator and the calibration cup.
14. Store the components of the calibration kit in a safe and convenient place.
15. Remove the voltmeter leads from the test points.
16. Secure the junction box cover to the junction box.

Maintenance

This section describes maintenance procedures. It includes preventive maintenance, troubleshooting, and component replacement procedures.

Preventive Maintenance

This section describes a preventive maintenance schedule to ensure the optimum performance of the CO transmitter. It includes daily and quarterly procedures.

Daily

Verify a display reading of 0 PPM CO at the controller. Investigate significant changes in the display reading.

Quarterly

Calibrate the CO transmitter as described in “Calibration” on page 17 of this manual. See the calibration frequency discussion in “Calibration Frequency” on page 17 to determine if a quarterly calibration schedule fits your needs.

Troubleshooting

The troubleshooting guide describes symptoms, probable causes, and recommended action for problems you may encounter with the CO transmitter.

NOTE: This troubleshooting guide describes transmitter problems only. See the controller operator’s manual for problems you may encounter with the controller.

Table 2: Troubleshooting the CO Transmitter

Condition	Symptom(s)	Probable Causes	Recommended Action
Fail Condition	Controller indicates a fail condition.	<ul style="list-style-type: none"> • The transmitter wiring to the controller is disconnected or misconnected. • The wiring from the detector to the amplifier is disconnected or misconnected. • The plug-in sensor is not properly plugged into the four-socket pattern in the detector housing body. • The transmitter’s zero reading is low enough to cause a fail condition. • The transmitter is malfunctioning. 	<ol style="list-style-type: none"> 1. Verify that the transmitter wiring to the controller is correct and secure. 2. Verify that the wiring from the detector to the amplifier is correct and secure. 3. Confirm that the plug-in sensor is properly installed. 4. Perform a zero adjustment. A full calibration is recommended. 5. If the fail condition continues, replace the sensor as described later in this section. 6. If the fail condition continues, contact RKI for further instruction.

Table 2: Troubleshooting the CO Transmitter (cont.)

Condition	Symptom(s)	Probable Causes	Recommended Action
Slow or No Response/ Difficult or Unable to Calibrate	<ul style="list-style-type: none"> • Unable to accurately set the zero or response reading during calibration. • Transmitter requires frequent calibration. <p><i>Note: Under “normal” circumstances, the transmitter requires calibration once every 3 months. Some applications may require a more frequent calibration schedule.</i></p>	<ul style="list-style-type: none"> • The calibration cylinder is low, outdated, or defective. • The calibration gas is not an appropriate concentration. • The membrane on the detector housing cap is blocked with dirt or some other particulate matter. • The transmitter is malfunctioning. 	<ol style="list-style-type: none"> 1. Verify that the calibration cylinder contains an adequate supply of a fresh test sample. 2. Check the face of the detector housing cap and remove any particulate contamination from the hydrophobic membrane if necessary. 3. Verify that the calibration gas concentration is appropriate for the transmitter. Zero emission air (20.9% oxygen) is normally used for a zero adjustment if the environment is suspect and 50 PPM CO in air is normally used for a response adjustment. 4. If the calibration/response difficulties continue, replace the sensor as described later in this section. 5. If the calibration/response difficulties continue, contact RKI for further instruction.
Unexplained Upscale Readings or Alarms	<ul style="list-style-type: none"> • Controller indicates a CO reading that cannot be verified. • CO alarms occur at the controller that cannot be explained. 	<ul style="list-style-type: none"> • Charcoal filter is saturated and no longer scrubbing out interfering gases. 	<ol style="list-style-type: none"> 1. Replace charcoal filter. 2. If difficulties continue, contact RKI for further instruction.

Replacing Components of the CO Transmitter

This section includes a procedure to replace the CO plug-in sensor, charcoal filter, and amplifier. A procedure to replace the entire detector assembly is at the end of this section. In most cases, it is not necessary to replace the entire detector assembly.

Replacing the Plug-In CO Sensor

CAUTION: *The sensor contains electrolyte which is a dilute acid. Do not disassemble the sensor when replacing it with a new one. If sensor electrolyte comes in contact with your skin, wash affected area thoroughly with soap and water.*

1. Turn off the controller.
2. Turn off or unplug power to the controller.
3. Unscrew the detector housing cap from the detection housing body. Make sure not to lose the cap gasket.

4. Unplug and remove the CO plug-in sensor with the boot and charcoal filter attached.
5. Remove the rubber boot and charcoal filter from old sensor.
6. Remove the replacement sensor from its packaging and remove the wire jumper. This wire jumper is installed on the sensor pins for shipment or storage but must be removed for the sensor to operate properly when installed in a detector.

WARNING: *The sensor will not operate properly if the wire jumper is not removed.*

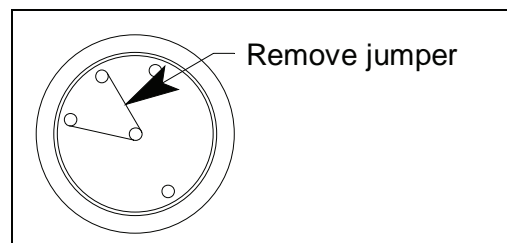

Figure 5: Plug-In Sensor Jumper Removal

7. Install the rubber boot with charcoal filter onto the replacement sensor's face.
8. Carefully plug the replacement sensor into the four-socket pattern that is located in the detector housing.
9. Make sure the cap gasket is in place and screw the detector housing cap back onto the detector housing body.
10. Turn on or plug in power to the controller.
11. Turn on the controller and place it into normal operation.

CAUTION: *Allow the replacement sensor to warm up for 5 minutes before you continue with the next step.*

12. Calibrate the transmitter as described in "Calibration" on page 17.

Replacing the Charcoal Filter

1. Turn off the controller.
2. Turn off or unplug power to the controller.
3. Unscrew the detector housing cap from the detector housing body.
4. Unplug and remove the CO plug-in sensor with the boot and charcoal filter attached.
5. Remove the rubber boot that secures the charcoal filter to the CO plug-in sensor.
6. Remove the charcoal filter from the rubber boot.
7. Place the replacement filter in the rubber boot in the same position as the filter you removed in the previous step.
8. Reinstall the rubber boot with charcoal filter to the CO plug-in sensor.
9. Carefully plug the replacement plug-in sensor into the four-socket pattern that is located in the top section of the detector housing.
10. Make sure the cap gasket is in place and screw the detector housing cap back onto the detector housing body.

11. Turn on or plug in power to the controller.
12. Turn on the controller and place into normal operation.

Replacing the CO Detector

NOTE: In most cases, it is only necessary to replace the CO plug-in sensor.

1. Turn off the controller.
2. Turn off or unplug power to the controller.
3. Remove the junction box cover.
4. Remove the detector terminal strip from its socket.
5. Disconnect the detector leads from the detector terminal strip. Note the position of the color-coded leads as you remove them.
6. Unscrew the detector from the junction box.
7. Guide the detector leads of the replacement detector through the bottom conduit hub of the junction box, then screw the mounting threads of the detector into the conduit hub. If necessary for environmental conditions, apply thread sealant or Teflon tape to the hub and/or detector threads to seal them.
8. Connect the detector leads to the appropriate detector terminal strip terminals. Connect the red wire to the terminal labeled TOXIC+ and the black wire to the terminal labeled TOXIC-. See Figure 4 for the detector wiring connections to the amplifier.
9. Reinstall the detector terminal strip into its socket.
10. Turn on or plug in power to the controller.
11. Turn on the controller and place it into normal operation.

CAUTION: Allow the replacement detector to warm up for 5 minutes before you continue with the next step.

12. Calibrate the replacement detector as described in “Calibration” on page 17.
13. Secure the junction box cover to the junction box.

Replacing the Amplifier

1. Turn off the controller.
2. Turn off or unplug power to the controller.
3. Remove the junction box cover.
4. Unplug the detector terminal strip and controller terminal strip from their sockets. You may leave the wires connected to the terminal strips.
5. Unscrew and remove the screw with the flat lock and washers that secures the amplifier to the junction box. The screw is at the bottom right of the amplifier.
6. Remove the amplifier.
7. Place the new amplifier in the same position as the old amplifier. A foam gasket that orients the amplifier and keeps it from rotating is installed on the bottom of the amplifier. Make sure the amplifier is seated flat in the junction box.

8. Install the new amplifier into the junction box with the screw, lock washer, and flat washer you removed in Step 5.
9. Install the detector and controller terminal strips into their sockets on the new amplifier as shown in Figure 4. If controller leads or detector leads were removed during this procedure, refer to Figure 4 for the detector and amplifier connections.

NOTE: When a transmitter is first powered up with a new amplifier, the initial output may be either high or below zero depending on the setting of the zero pot. Be sure to make arrangements so that this does not cause unwanted alarms.

10. Turn on or plug in power to the controller.
11. Turn on the controller and place it into normal operation.
12. Allow the transmitter to warm up for 5 minutes.
13. Calibrate the CO transmitter as described in “Calibration” on page 17.

Calibration Frequency

Although there is no particular calibration frequency that is correct for all applications, a calibration frequency of every 3 months is adequate for most CO transmitter applications. Unless experience in a particular application dictates otherwise, RKI Instruments, Inc. recommends a calibration frequency of every 3 months for the CO transmitter.

If an application is not very demanding, for example detection in a clean, temperature controlled environment, and calibration adjustments are minimal at calibration, then a calibration frequency of every 6 months is adequate.

If an application is very demanding, for example if the environment is not well controlled, then more frequent calibration than every 3 months may be necessary.

Calibration

This section describes how to calibrate the CO transmitter. It includes procedures to prepare for calibration, set the zero reading, set the response reading, and return to normal operation. It describes the test using a calibration kit that includes a calibration cup, calibration gas, sample tubing, and a fixed flow regulator with an on/off knob. RKI Instruments, Inc. recommends using a 0.5 LPM (liters per minute) fixed flow regulator.

Preparing for Calibration

NOTE: Calibrating the CO transmitter may cause alarms. Be sure to put the controller into its calibration program or disable external alarms before calibrating.

1. Unscrew and remove the junction box cover.
2. Set a voltmeter to measure in the millivolt (mV) range.
3. Plug the voltmeter leads into the test points on the amplifier.
Plug the positive lead into the red (+) test point; plug the negative lead into the black (-) test point.

4. Use the following formula to determine the correct test points output for the calibrating sample.

$$\text{Output (mV)} = (\text{calibrating sample/fullscale}) \times 400 + 100$$

For example, with a calibrating sample of 50 PPM CO and a fullscale setting of 300 PPM, the correct output is 167 mV.

$$167 \text{ (mV)} = (50/300) \times 400 + 100$$

5. Screw the calibration cup onto the detector housing.

Setting the Zero Reading

NOTE If you can verify that the CO transmitter is in a fresh air environment, you do not need to apply zero air to the detector before adjusting the zero reading.

1. Screw the regulator into the zero air calibration cylinder.
2. Use the sample tubing to connect the regulator to the calibration cup.
3. Turn the regulator knob counterclockwise to open the regulator.
4. Allow the gas to flow for two minutes, then verify a reading of 100 mV ($\pm 2\text{mV}$). If necessary, use the zero pot on the amplifier to adjust the reading to 100 mV ($\pm 2\text{mV}$).
5. Turn the regulator knob clockwise to close the regulator.
6. Unscrew the regulator from the zero air calibration cylinder.
7. Leave the sample tubing connected to the regulator and the calibration cup.

Setting the Response Reading

1. Screw the regulator into the calibration cylinder. Verify that the calibration gas is representative of the transmitter's target gas.
2. Turn the regulator knob counterclockwise to open the regulator.
3. Allow the gas to flow for two minutes, then verify that the reading matches the response reading ($\pm 2\text{mV}$) you determined earlier. If necessary, use the span pot on the amplifier to adjust the reading to match the correct response reading.
4. Turn the regulator knob clockwise to close the regulator.
5. Unscrew the regulator from the calibration cylinder.

Returning to Normal Operation

1. Remove the voltmeter leads from the amplifier test points.
2. Unscrew the calibration cup from the detector.

NOTE: For convenience, leave the components of the calibration kit connected by the sample tubing.

3. Secure the junction box cover to the junction box.
4. When the display reading falls below the alarm setpoints, return the controller to normal operation.
5. Verify that the controller display reading decreases and stabilizes at 0 ppm.
6. Store the components of the calibration kit in a safe and convenient place.

Parts List

Table 3 lists replacement parts and accessories for the CO transmitter.

Table 3: Parts List

Part Number	Description
06-1248RK	Calibration kit sample tubing, 3 foot length
07-0039RK	Detector housing cap gasket
07-0203RK	Rubber retaining boot (for charcoal filter)
18-0405RK	Junction box (without cover; pre drilled for amplifier)
18-0406RK	Junction box cover
33-7101RK	Charcoal filter disk
57-1064RK-03	Toxic amplifier with orienting gasket
65-2335RK	CO transmitter, non-explosion proof, includes detector and amplifier
65-2496RK	CO replacement detector, includes sensor
71-0177RK	65-2335RK Operator's Manual (this document)
81-0064RK-01	Calibration cylinder, 50 PPM CO in air, 34 liter steel
81-0076RK-01	Zero air calibration cylinder, 34 liter steel
81-1050RK	Regulator, with gauge and knob, 0.5 LPM, for 17 liter and 34 liter steel calibration cylinders (cylinders with external threads)
81-1051RK	Regulator, with gauge and knob, 0.5 LPM, for 34 liter aluminum/58 liter/103 liter calibration cylinders (cylinders with internal threads)
81-1117RK	Calibration cup
ES-1531-CO	CO replacement sensor