



Heavy-Duty Vortex Mixers



Increase Productivity with Continuous-Duty Vortexing of Multiple Samples

OHAUS Heavy-Duty Vortex Mixers feature a robust design and the highest quality motor to permit continuous-duty operation with accessories over the entire speed range. Digital models offer a timer and exact speed control when applications demand repeatable results. Non-digital variable speed models are an economical alternative. A wide range of accessories are available for microtubes, microplates and a variety of tube sizes from 0.5 to 50 ml.

Standard Features:

- Safe to mix at high speeds - the unique locking design of the mixer accessories allows the mixer to safely operate throughout the entire speed range.
- For the most demanding applications, these mixers utilize a high quality German-manufactured motor, allowing for continuous duty operation and increased load capacities up to 1.1 kg.
- Robust digital and non-digital models offer effective speed control from low rpm for gentle shaking to high-speed mixing for vigorous vortexing of difficult samples.

Heavy-Duty Vortex Mixers

Model	VXHDAL	VXHDDG
Control	Analog	Digital
Speed Range	On Mode, 300 rpm – 2500 rpm, Touch Mode, 300 rpm – 3500 rpm	
Orbit	4.9 mm	
Duty Rating	Continuous	
Capacity	2.5 lb / 1.1 kg	
Working Environment	39 °F – 104 °F, 20% – 85% RH*, non-condensing / 4 °C – 40 °C, 20% – 85% RH*, non-condensing	
Power	120V, 0.25A, 50/60Hz	
Power Consumption	30 W	
Dimensions (W × L × H)	6.6 × 9.5 × 6.3 in. / 168 × 241 × 160 mm	
Net Weight	14.8 lb / 6.7 kg	

*Relative Humidity

Other Standard Features and Equipment

Detachable 3-wire cord and plug (included), universal holder, foam insert for (38) 1.5 to 2 mL microtubes, universal cover and cup head (included)

Compliance

- **Product Safety:** CAN/CSA C22.2 61010-1, CAN/CSA C22.2 61010-2-051, UL 61010-1
- **Electromagnetic Compatibility:** ICES-003 Class A, FCC Part 15 Class A
- **Compliance Marks:** TÜV SÜD

Accessories

Foam Insert Blank	30400209
Cup Head, VXHD and VXMP Vortex Mixers	30400210
Large Vessel Holder For 500 mL/1 L Flask	30400211
4 Place Stackable Microplate Holder	30400212
Double Microplate Holder	30400213
4 Place Microplate Holder	30400214
Single Microplate Holder	30400215
Foam Insert For (52) 0.5 mL Microtubes	30400216
Foam Insert (38) 1.5-2.0 mL Microtubes	30400217
Small Vessel Holder 125 & 250 mL Flasks	30400218
Single Tube Holder, VXHD Vortex Mixers	30400219
Foam Insert For (34) 12-13 mm Tubes	30400220
Foam Insert For (20) 15-18 mm Tubes	30400221
Foam Insert For (18) 19-21 mm Tubes	30400222
Foam Insert For (13) 22-25 mm Tubes	30400223
Foam Insert For (4) 26-29 mm Tubes	30400224
Cover For Universal Holder	30400225
Universal Holder	30400226

Dimensions

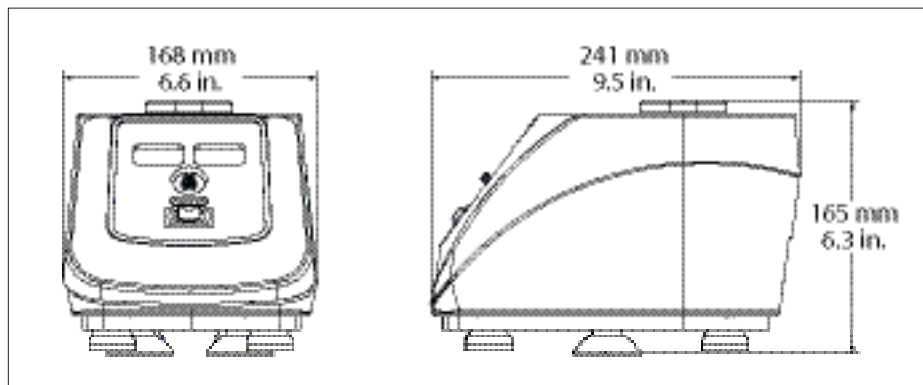

OHAUS CORPORATION

The management system governing the manufacture of this product is ISO 9001:2015 certified.

75561_A 20190504 © Copyright OHAUS Corporation

