

AC Current Probe Model MN103

User Manual

DESCRIPTION

The **Model MN103** (Catalog #1031.02) measures leakage current and low currents from 1 mA, and measures current on 5 A secondaries. This current probe provides AC current measuring capabilities to instruments with mV inputs. The **Model MN103** offers a 5 ft lead with safety 4 mm banana plug.

WARNING

These safety warnings are provided to ensure the safety of personnel and proper operation of the instrument.

- Read the instruction manual completely and follow all the safety information before attempting to use or service this instrument.
- Use caution on any circuit: Potentially high voltages and currents may be present and may pose a shock hazard.
- Read the Safety Specifications section prior to using the current probe. Never exceed the maximum voltage ratings given.
- Safety is the responsibility of the operator.
- ALWAYS connect the current probe to the display device before clamping the probe onto the sample being tested.
- ALWAYS inspect the instrument, probe, probe cable, and output terminals prior to use. Replace any defective parts immediately.
- NEVER use the current probe on electrical conductors rated above 250 V. Use extreme caution when clamping around bare conductors or bus bars.

INTERNATIONAL ELECTRICAL SYMBOLS



This symbol signifies that the current probe is protected by double or reinforced insulation. Use only factory-specified replacement parts when servicing the instrument.



This symbol signifies **CAUTION!** and requests that the user refer to the user manual before using the instrument.



This symbol signifies that this is a type A current sensor and that application near and removal from **HAZARDOUS LIVE** conductors is permitted.

DEFINITION OF MEASUREMENT CATEGORIES (CAT)

CAT IV: For measurements performed at the primary electrical supply (< 1000 V), such as primary overcurrent protection devices, ripple control units, or meters.

CAT III: For measurements performed in the building installation at the distribution level, such as hardwired equipment in fixed installation or circuit breakers.

CAT II: For measurements performed on circuits directly connected to the electrical distribution system, such as measurements on household appliances or portable tools.

RECEIVING YOUR SHIPMENT

Upon receiving your shipment, make sure that the contents are consistent with the packing list. Notify your distributor of any missing items. If the equipment appears to be damaged, file a claim immediately with the carrier and notify your distributor providing a detailed description of any damage.



INSTRUMENT COMPATIBILITY

The Model MN103 is compatible with any AC voltmeter, multimeter, or other voltage measurement instrument with an input impedance of 100 k Ω or greater. To achieve the stated accuracy, use the MN103 with a voltmeter having an accuracy of 1 % or better.

CURRENT PROBE - MN103 DRAWING

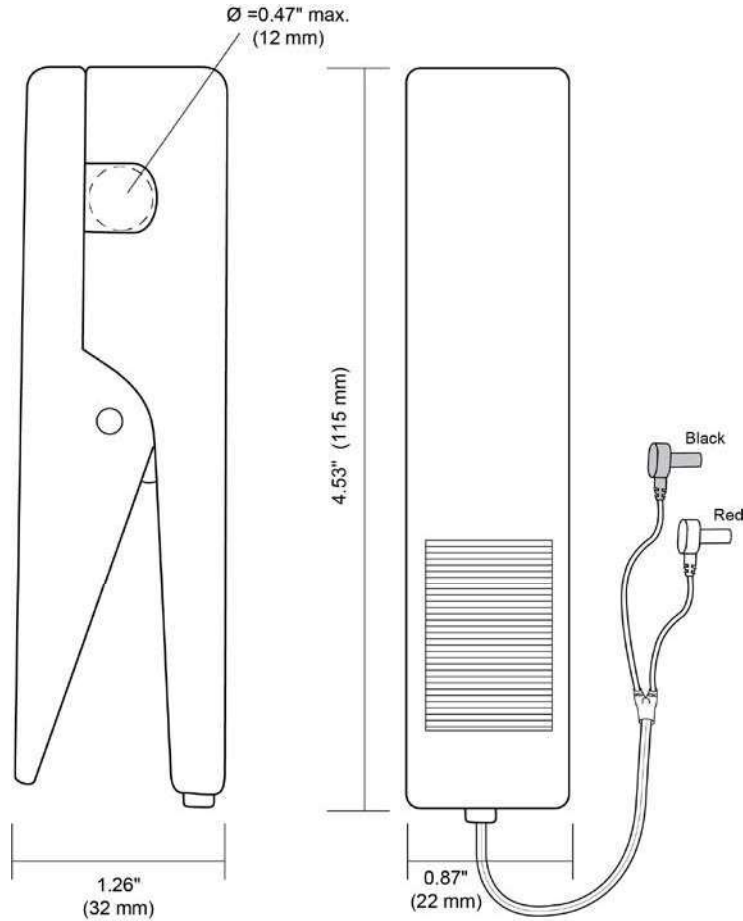

ELECTRICAL SPECIFICATIONS

Current Range (low):

10 A: 1 mA to 10 AAC

Output Signal:

1 mV AC/mAAC (10 V @ 10 A)

Accuracy*:

Accuracy: 1 mA to 10 AAC
(45 to 65) Hz: $\pm 3\%$ Reading ± 1 mA
> (65 to 500) Hz: -2, +6 % Reading ± 1 mA

Current Range (high):

100 A: (1 to 100) AAC

Output Signal:

1 mV AC/AAC
(100 mV @ 100 A)

Load Impedance:

100 K Ω min

Accuracy*:

Accuracy: 1 A to 100 AAC
 (45 to 65) Hz: $\pm 2\%$ Reading ± 0.1 A
 > (65 to 500) Hz: -2, +3 % Reading ± 0.1 A

*Reference conditions: 23 °C ± 3 °K,
 (20 to 70) % RH, external magnetic field
 < 40 A/m, no DC component, no external
 current carrying conductor, test sample
 centered. Load impedance 1 M Ω .

Frequency Range:

(45 to 500) Hz

Working Voltage: 250 VAC

Common Mode Voltage: 250 VAC

Calibration Check:

Recommended once a year

MECHANICAL SPECIFICATIONS**Operating Temperature:**

(14 to 122) °F (-10 to 50) °C

Storage Temperature:

(40 to 176) °F (-40 to 80) °C

Maximum Cable Diameter:

0.47 in \varnothing max. (12 mm)

Dimensions:

(1.26 x 4.53 x 0.87) in (32 x 115 x 22) mm

Weight:

5.6 oz (160 g)

Polycarbonate Material:

Handle: 10 % Fiberglass charged polycarbonate UL 94 V0

Output:

MN103: Double/reinforced insulated
 5 ft (1.5 m) lead with safety 4 mm banana
 plug

SAFETY SPECIFICATIONS**Electrical (IEC 414):**

250 V working voltage

250 V max common mode between output
 and ground

3 kV 50/60 Hz dielectric for 1 min

ORDERING INFORMATION

AC Current Probe MN103.....Cat #1031.02

Accessories:

Banana plug adapter

(to non-recessed plug)Cat #1017.45

OPERATION**Making Measurements with the AC Current Probe Model MN103**

- Connect the black lead of the current probe to “common” and the red lead to the AC voltage range on your DMM or other voltage measuring instrument. The “10 A” range has an output signal of 1 mV/mA AC. This means that for 10 AAC in a conductor around which the probe is clamped, 10 VAC will come out of the probe leads to your DMM or instrument. The “100 A” range has an output signal of 1 mV/AAC. This means that for 100 AAC in a conductor around which the probe is clamped, 100 mVAC will come out of the probe leads to your DMM or instrument. Select the range on your DMM or instrument which corresponds best to the measured current. If the current magnitude is unknown, start with the highest range first and work down until the appropriate range and resolution is reached. Clamp the probe around the conductor. Take the reading on the meter and multiply it by the output signal used to obtain the measured current. (e.g. If the meter reads 100.5 mV [range 1 mV/mA], then current equals 100.5 mAAC). Unclamp the probe from the conductor before disconnecting it from your DMM or instrument.
- For best accuracy, avoid if possible, the proximity of other conductors which may create noise.

Tips for Making Precise Measurements

- When using a current probe with a meter, it is important to select the range that provides the best resolution. Failure to do this may result in measurement errors.
- Make sure that probe jaw mating surfaces are free of dust and contamination. Contaminants cause air gaps between the jaws, increasing the phase shift between primary and secondary. It is very critical for power measurement.

MAINTENANCE

Warning

- For maintenance, use only original replacement parts.
- To avoid electrical shock, do not attempt to perform any service on the device unless you are qualified to do so.
- To avoid electrical shock and/or damage to the instrument, do not allow water or other foreign agents to come into contact with the probe.

Cleaning

To ensure optimum performance, it is important to keep the probe jaw mating surfaces clean at all times. Failure to do so may result in error in readings. To clean the probe jaws, use very fine sand paper (fine 600) to avoid scratching the jaw, and then gently clean with a soft, oiled cloth.

REPAIR AND CALIBRATION

You must contact our Service Center for a Customer Service Authorization number (CSA#). This will ensure that, when your instrument arrives, it will be tracked and processed promptly. Please write the CSA# on the outside of the shipping container.

Ship To:



NOTE: You must obtain a CSA# before returning any instrument.

TECHNICAL AND SALES ASSISTANCE

If you are experiencing any technical problems, or require any assistance with the proper operation or application of your instrument, please call, e-mail or fax our technical support team:

Contact:

LIMITED WARRANTY

The current probe is warranted to the owner for a period of two years from the date of original purchase against defects in manufacture. This limited warranty is given by AEMC® Instruments, not by the distributor from whom it was purchased. This warranty is void if the unit has been tampered with, abused, or if the defect is related to service not performed by AEMC® Instruments.

Full warranty coverage and product registration is available on our website at:

Please print the online Warranty Coverage Information for your records.

99-MAN 100019.v13 03/23