

SHIMPO

NIDEC-SHIMPO AMERICA CORPORATION

A *Nidec* Group Company

Model DT-311J

And

DT-311J-230V(AC)

DIGITAL STROBOSCOPE

INSTRUCTION MANUAL





.....
NIDEC-SHIMPO AMERICA CORPORATION

A Nidec Group Company

1. GENERAL

The DT-311J DIGITAL STROBOSCOPE is designed to assist mechanical timing adjustments and emit flashes synchronously with an external signal and an internal signal. Flashes can be delayed continuously from 0 up to 359 degrees at a positive edge of an external signal by regulating the adjustment knob and the delayed angle is shown on the LED display. Zero position can be set to any optimal synchronous position. Revolutions per minute (RPM) can also be displayed.

IMPORTANT SAFETY INSTRUCTIONS

Do not apply a strong shock or rapid temperature change to the unit. Especially, do not leave it where temperature will rise: for instance, in a closed automobile, exposed to direct sunlight, near a stove, open flame, etc. This instrument is protected against water drips. Do not spray or immerse in water. Do not open and disassemble the unit. Make sure of proper voltage!

- (1) Do not use stroboscope in an explosive atmosphere as it generates high electrical energy pulses.
- (2) To avoid potential eye damage, do not look directly at flashes.
- (3) Before operation, make sure there is no damage on the provided AC voltage line cable. If the cable is damaged, replace it with a new one.
- (4) To protect against water drips, carefully thread the power cable connector firmly to the stroboscope. After metal connector of the cable has been properly fitted onto the body, the power cable can then be safely plugged into a properly grounded AC receptacle.



NIDEC-SHIMPO AMERICA CORPORATION

A Nidec Group Company

2. SPECIFICATIONS

(1) Flashing range	200 – 1,500 rpm
(2) Phase shift	0 – 359°
(3) Internal signal range	200 up to 1,500 rpm
(4) Delay setter	ROTARY ENCODER
(5) Display	4 digits, 10mm high, Red LED
(6) Divided ratio	1/1, 1/2, 1/3, 1/4, 2/4 with shift
(7) Input signal	High level, 5 to 24v pulse width, 2 msec min. Low level, 0 to 1v pulse width, 2 msec min. 1p/r. Output impedance less than 10k ohms
(8) Input impedance	47k ohms
(9) Display mode	phase shift (degree), Tachometer
(10) Accuracy	+/- 1 digit
(11) Flash tube	Xenon lamp: Max 10W at 1,500 rpm Life: 100 million flashes
(12) Operating temperature	32° - 104° F (0 - 40° C)
(13) Power requirement	110 VAC, (230VAC model) +/-10% at 50/60 Hz
(14) Power consumption	20 VA MAX
(15) Dimensions	8.43"L x 5.87"W x 6.85"H (214 mm x 149 mm x 174 mm)
(16) Weight	4.19 lb (1.9kg)
(17) Accessories included	6m (19') cable with connector, 1 pc. Instruction manual, warranty card

3. DIAGRAM

A. Front panel

- (1) Xenon lamp
- (2) Protective window
- (3) Protective window screws
- (4) Reflector
- (5) Handle

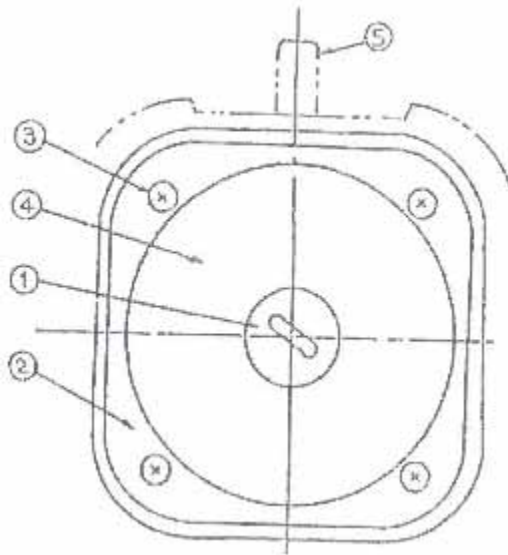

B. Rear (Display & Operation panel)

- (1) Delayed angle or rpm display
- (2) Mode indicators

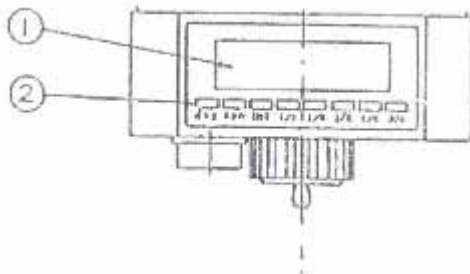

- (3) Power switch
- (4) Connector
- (5) Mode select switch
- (6) Setting knob: for Flash Rate and Phase Shift adjustment
- (7) Zero setting switch
- (8) Divide ratio select switch
- (9) Stroboscope flash: on/off switch
- (10) Shift switch

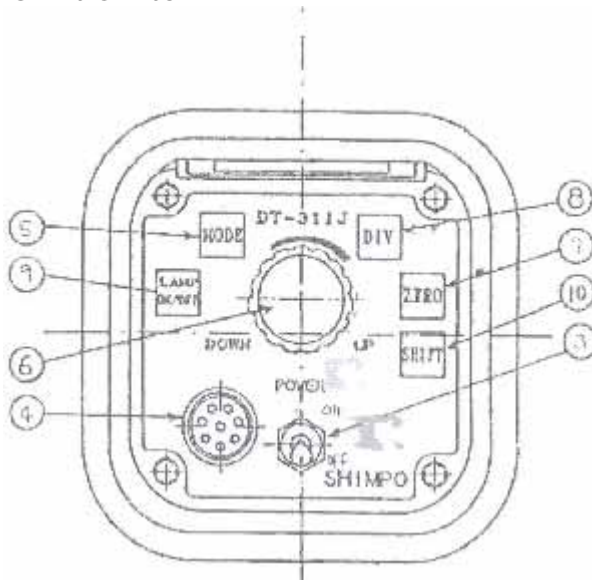

4. CABLE CONNECTION

Connect power and signal with provided cable as follows:

AC plug (with 3-prong plug)	110 VAC or 230VAC at 50/60 Hz
Red clip	Signal (positive)
Black clip	0V

5. MODE SELECTION

Press (MODE) switch (5) to select internal or external signal mode.



NIDEC-SHIMPO AMERICA CORPORATION

A Nidec Group Company

6. INTERNAL SIGNAL OPERATION

When internal signal mode is selected ('INT' LED on), flash rate is adjusted by turning the setting knob (6).

7. EXTERNAL SIGNAL OPERATION

When external signal mode is selected ('deg' or 'rpm' LED on), flashing rate is synchronized with the external signal.

Deg rpm	Delayed angle # of revolutions per 1 minute	Degree rpm
------------	--	---------------

(1) DIVIDE RATIO SETTING (See 8. FLASH INTERVAL for detail)

Select 1/1 to provide a flash per every 1 rotation.

Select 1/2 to provide a flash per every 2 rotations.

Select 1/3 to provide a flash per every 3 rotations.

Select 1/4 to provide a flash per every 4 rotations.

Select 2/4 to provide two continuously flashes per 4 rotations.

(2) PHASE SHIFT

Turning the Phase shift setting knob clockwise or counterclockwise, the flashing phase will be shifted.

Pressing the zero set button (ZERO) makes the display "0" at any angle.

8. FLASH INTERVAL

(1) FLASH MODE

Flashing behavior at each mode.

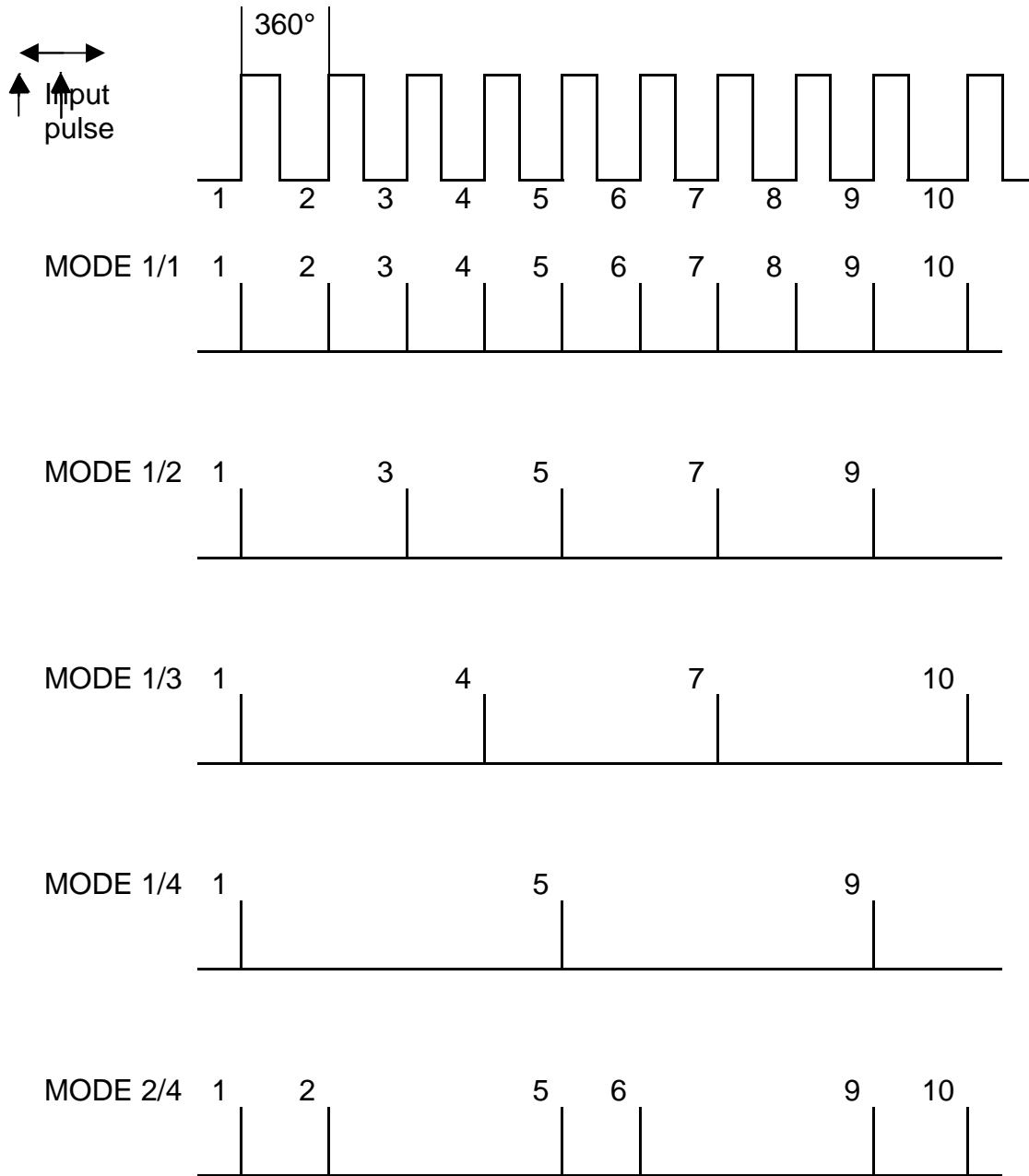



NIDEC-SHIMPO AMERICA CORPORATION

A Nidec Group Company

Every time you depress the shift button (SHIFT), the flashes slide to the next pulse.

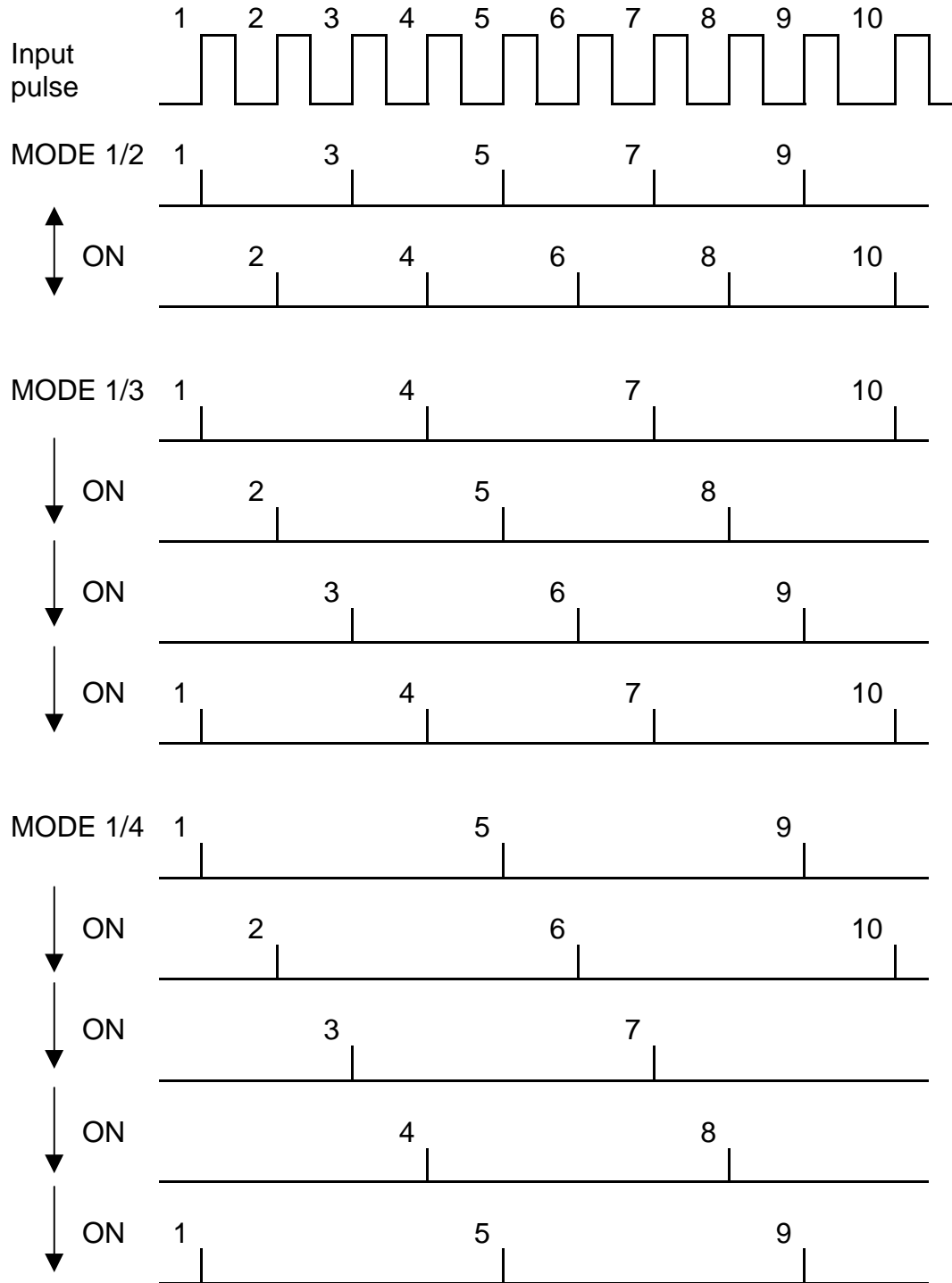



NIDEC-SHIMPO AMERICA CORPORATION

A Nidec Group Company

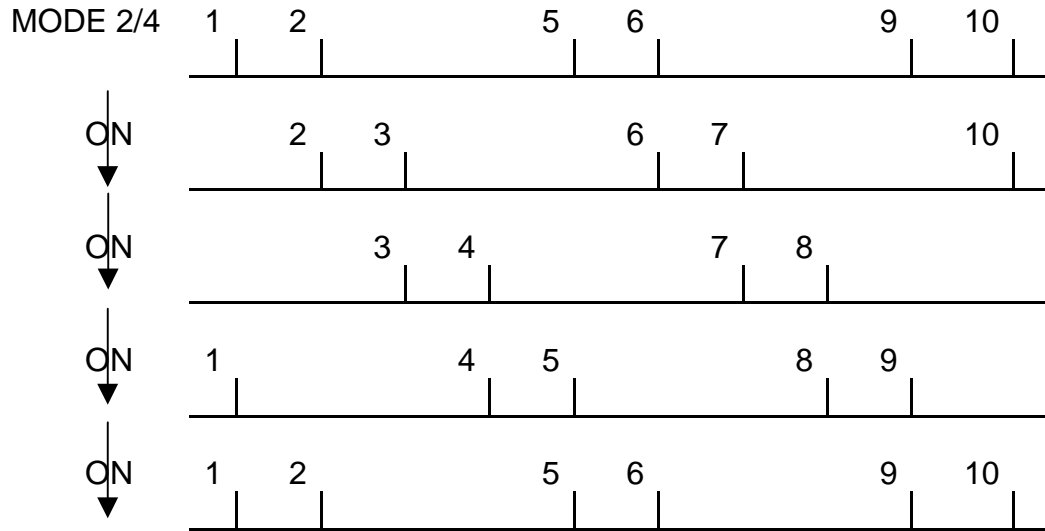

9. LAMP ON/OFF SWITCH

LAMP ON/OFF switch provides power to the lamp. To save the flash tube and general lamp life, turn the lamp off when not in operation.

Once power is applied and no adjustments are made during the next 30 minutes, the flashing will automatically turn off the lamp causing the display to flash rapidly. To continue operation, press the LAMP ON/OFF switch and the flashing will continue. for another 30 minutes.

10. ALARMS

1. LOW SPEED INDICATOR (External signal operation only)
Below 180 rpm, the "under" symbol appears.

At degree mode

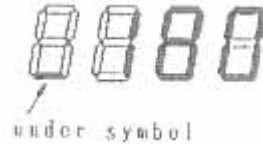

At rpm mode



2. HIGH SPEED INDICATOR (External signal operation only)

Over 1,550rpm "over" symbol appears.

At degree mode



At rpm mode

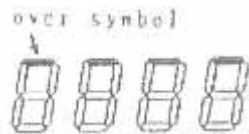

If AC power is low, the flashing will stop and "LLLL" will be displayed.
If an alarm symbol appears, ("under", "over") the stroboscope flash will not function.

11. INPUT CIRCUITRY

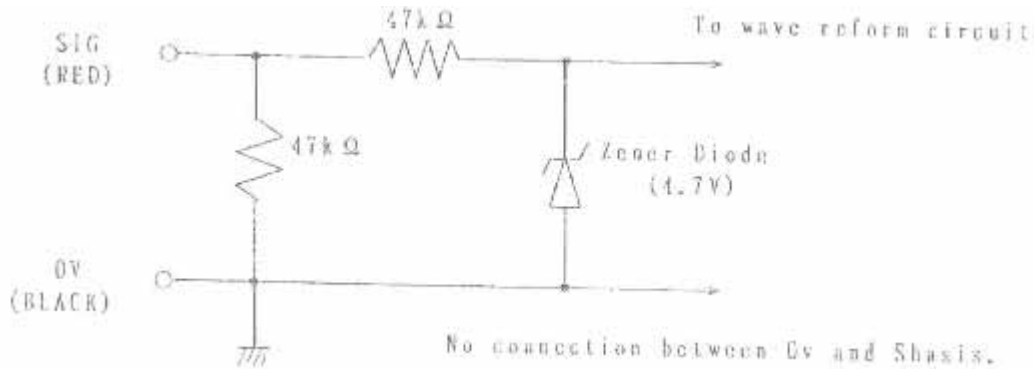

12. LAMP REPLACEMENT

Indications:

Lamp life is about 100 million flashes.

Rotation speed is displayed, no flash is emitted.

When the flash is intermittently emitted, this indicates the lamp must be replaced.

Only replace flash tube with the specified lamp: (FLASHTUBE311-J).

Directions:

- (1) After unplugging the line cable from the power line, let the stroboscope sit for about 30 minutes or longer. Be sure stroboscope is cool to the touch before replacing the lamp.
- (2) Remove the lamp protection window by loosening the 4 screws on the window. Insert a fine screw driver into a hole of the protection window and pull out.
- (3) Remove the reflector and pull out the lamp base. Caution, do not pull out the lamp glass directly.
- (4) Do not touch the flash tube with fingers. Use a clean cloth. Press the lamp base to the socket in the proper direction to install the new lamp.
- (5) Important: In order to maintain protection against water, be sure to mount the reflector in the center. Fix the reflector on the former position and fix the protective window with the 4 screws and the sealing washers.

SHIMPO

NIDEC-SHIMPO AMERICA CORPORATION

A *Nidec* Group Company

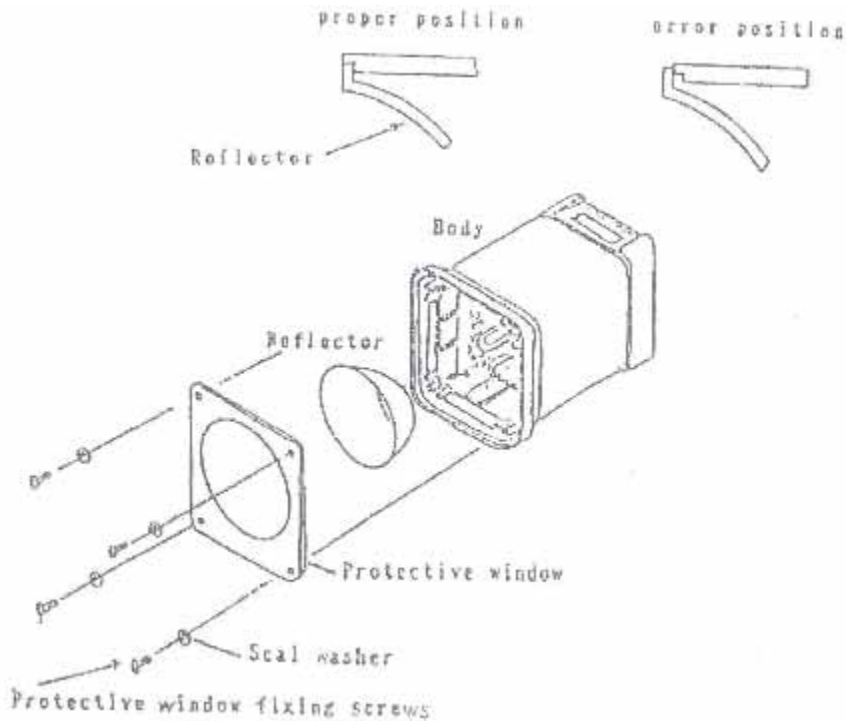

13. INITIAL RESET

Factory default settings: Simultaneously press the LAMP ON/OFF button and ZERO. Next press the "Power" switch on. The memory will be cleared and the factory default condition will resume.

Contact Shimpo Instruments with any questions or concerns:

Shimpo Instruments
1701 Glenlake Avenue
Itasca, IL 60143 USA
p: (800) 237-7079
f: (630) 924-0342
www.shimpointst.com
info@shimpointst.com